





# smart vision lights

*Where Innovation and Lighting Begin*

**Celebrating 10 years of service to the industrial lighting market.**

## AWARDS & ACCOLADES

2017 **Smart Vision Lights** won the Gold Innovators Award from Vision Systems Design magazine for the company's LM series miniature linear lights. The LM series is among the first lights to have our Multi-Drive™ internal driver, which allows the user to operate the light in either continuous or OverDrive™ strobe mode while delivering 5 to 10 times more light than competing lights of the same size and form factor.

2016 **Smart Vision Lights** won the Platinum Innovators Award from Vision Systems Design magazine for the company's line high power (LHP) series of LED lights for line scan imaging. The award is part of Vision Systems Design's Innovators Award program, which recognizes the top products and solutions in the machine vision and image processing industry, as determined by a panel of eight senior third-party expert judges. At 5 million lux, the LHP series of LED lights comprises the brightest line scan lights on the market. Smart Vision Lights' LHP is the first commercial machine vision LED light to use silicone optics. Optical-grade silicone will revolutionize machine vision lighting by enabling injection molding of complex optical designs that combine the best properties of glass and plastics, offering excellent light transmission, thermal resistance, and flexibility at a low cost.

2014 **Smart Vision Lights** was named to the Michigan 50 Companies to Watch, which honors second-stage businesses from a range of industries in the state. The Michigan Celebrates Small Business awards program selects companies for their impressive growth in jobs and revenue, as well as strength in leadership, corporate culture, community support and philanthropy, market reach, technology innovations, and other factors that contribute to an outstanding organization. Between 2010 and 2013, these companies collectively added 839 jobs and generated \$340 million in revenue. Together, they represent Michigan's vibrant entrepreneurial culture.



## CONTENTS

---

4	Vision Statement
5	Ordering Made Easy
6	Area Lights
7	Backlights
10	Brick Lights
13	Camera to Light
14	Controller to Light
15	Custom Lights
16	Dark Field Lights
18	Diffuse Ring Light Panels
20	Dome Lights
22	Dual-Axis Diffuse Line Scan
23	Dual-Axis RGB Lights
24	EZ Mount Ring Lights
29	High-Speed Strobe Lights
30	Large Area Ring Lights
32	LED Structured Light Pattern Projectors
34	Line High-Power Lights & Chillers
36	Linear Lights (Bar)
44	Mini Lights
46	Prox Spot Lights
50	TSLOT Extrusion LED Lights
51	Washdown Lights
56	Accessories & Kits
62	Safety Standard Compliance
63	10-Year Warranty

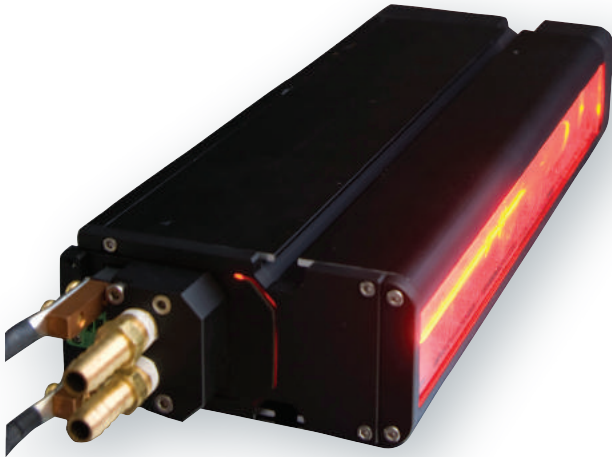

## OUR ADVANTAGES

---

- Machine vision industry's only 10-year warranty
- Fast delivery
- In-house LED testing laboratory ensures products meet IEC 62471 human eye and skin safety standards
- More than 75 years of combined machine vision light experience

## PRODUCT CATALOG

## VISION STATEMENT

**Smart Vision Lights** aims to be the preferred value-added LED lighting provider, known for its high-quality advanced innovative solutions.

## OUR CORE VALUES

*Servant Leadership, Ethical, Innovative, Collaborative, Financially Responsible, Accountable*

**Smart Vision Lights** is committed to these values and most importantly that of servant leadership. This means we put the needs of others before our own. We have built our culture on these core values and commit to being held accountable to them by our business partners and customers.

## MISSION STATEMENT

We are committed to delivering the most innovative effective lighting solutions with world-class products and service.

*This is our commitment to you.*

**Smart Vision Lights** makes it easy to find exactly what you're looking for!

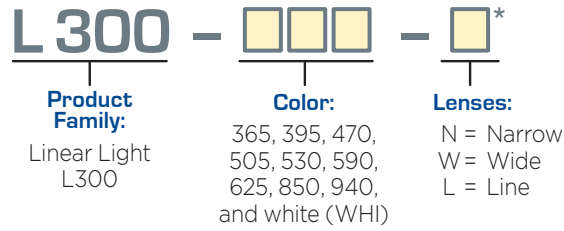

*\* Most lights come standard with narrow lenses. All lights are CE and RoHS compliant.*

## COLOR/WAVELENGTH

**Smart Vision Lights** products work with common and nonstandard wavelengths.\*



*\* Contact us for any custom wavelengths, including amber, dark red and maroon.*

## STANDARD LENS OPTICS

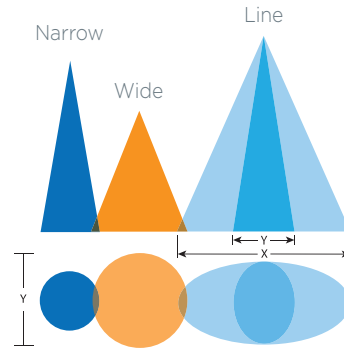

Additional lens options available upon request.

### ● **Narrow**

Narrow, 10° angle cone lenses are standard on most products. Standard lenses create a narrow beam of illumination and are used for long working distances.

### ● **Wide**

Wide, 25° angle cone lenses create a large area of illumination. They create a floodlight effect, can be used for short working distances.

### ● **Line**

Line, 10° and 50° angle cone lenses create a thin narrow beam of illumination when used on the L300 linear light.

**Smart Vision Lights'** OverDrive™ and Multi-Drive™ LED drivers integrate strobe and continuous operation modes for complete LED light control.



Our integrated intelligent Over-Drive™ driver monitors the strobe operation, maximizing output during vision system inspections.



The latest lights from Smart Vision Lights include our newest Multi-Drive™ driver, which allows the light to operate in constant output mode or in OverDrive™ strobe operation, depending on the needs of the application.

*Accessories and colors may change. Call for additional information.*

# Area Light

## Area Light | High Output

The Area Light (AL) Series of spot lights has the highest light output of any area light series in the Smart Vision Lights lineup. The Area Light features Multi-Drive™ built-in continuous operation and strobe capabilities. 45 mm industrial extrusion allows for greater heat dissipation due to the additional intensity.

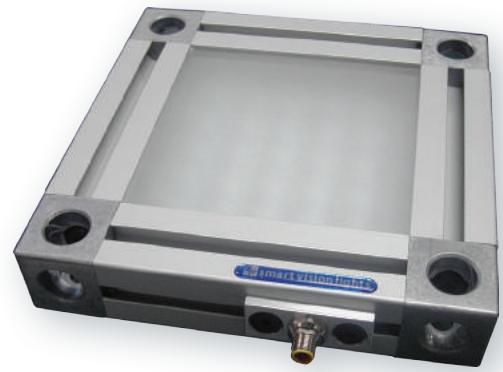

**AVERAGE INTENSITY RATING** 30,000 lux\* OverDrive™ 180,000 lux\*

\*Lux measurement taken at 1 m distance

## Area Light Features

- Built-in SMART driver – no external driver needed
- PNP and NPN strobe input
- Continuous operation or strobe mode
- Available in three sizes: 150 x 150 mm, 300 x 150 mm, and 300 x 300 mm

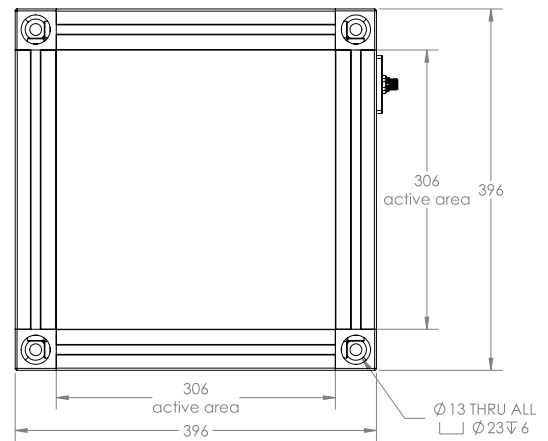
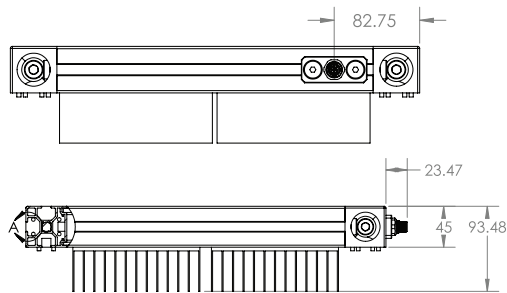

**PRODUCT FAMILY:**

Area Light  
AL

**SIZE:**

150 x 150  
300 x 150  
300 x 300

**COLOR:**

470, 505, 530,  
625, 850 &  
WHI (White)



## LARGE LIGHT PANEL Application

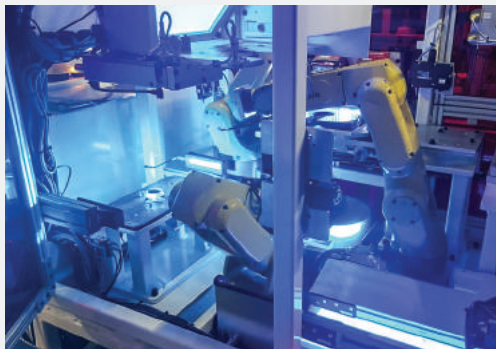

**Illumination:** LLP-305X305-470,  
LLP-500X250-470,  
LLP-1H-730X445-470

### BEVELED GLASS INSPECTION

**CLIENT REQUEST:** Client needed glue bead presence and measurement as part of a multi-camera, multi-part vision-guided robot inspection workcell.

**ISSUES:** The client needed the ability to detect and measure the position of a beveled metal frame around a glass panel, check for the presence- or absence of components, and measure the location of a glue bead. Using multiple cameras and large area panel lights, the system was able to accomplish all these tasks in a very small footprint.



**SOLUTION:** By placing a large, diffused light at 45- degrees to the camera's field of view, a 5-megapixel camera was easily able to differentiate between metal beveled edge and glass panel inside the metal frame. A separate large panel light was used to backlight bowl-fed components, while a third large panel backlight was used to differentiate between a cured glue bead and the glass panel.

# LLPX Edge-Lit Backlight

## LED Backlights | Large Light Panel

The second-generation LLP backlights and large diffuse ring light panels feature four-sided, edge-lit LED illumination for twice the intensity of our original versions. Standard sizing is available from 300 mm x 300 mm to 1800 mm x 1200 mm. Ask about custom sizes.

### LLPX Edge-Lit Backlight Features

- Built-in Multi-Drive™ driver
- PNP and NPN strobe input
- Continuous operation or strobe mode
- Analog intensity 0-10 V DC signal

**Customize this light:** Up to 3 wavelengths can be included in a single light.



**PRODUCT FAMILY:**

Backlight  
LLPX

**SIZE\*:**

306 x 306  
459 x 459

*\* Custom sizes upon request*

**COLOR:**

470, 530, 625  
& WHI (White)

*\* Other colors upon request*



<b>AVERAGE INTENSITY RATING</b>	8000 lux*	OverDrive™ 40,000 lux*
---------------------------------	-----------	------------------------

\*Lux measurement taken at surface of LLPX

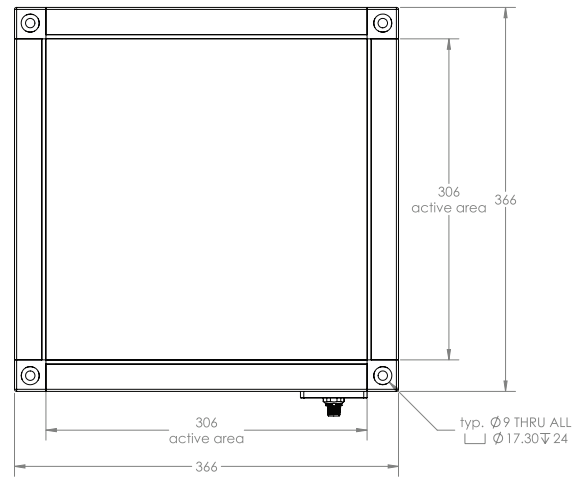

CAD drawings are 306 x 306 mm versions of LLPX.

### LLPX-WHI-LP with Polarizer Filter on Lens

Large panel backlights, like the **LLPX**, are great for highlighting the edges and adding contrast along edges of clear or translucent parts, such as the clear plastic catheters and bottles of cleaner shown here.

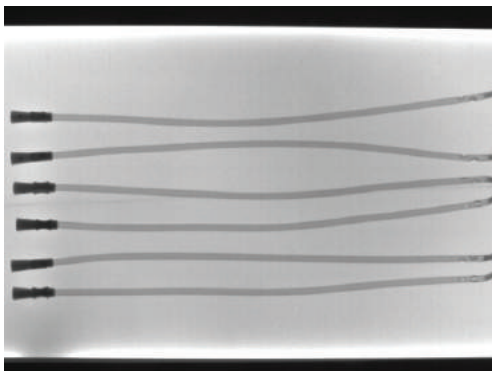

# MOBL Backlight

## LED Backlights | High-Output

With a thin profile of only 45 mm, the MOBL series of LED backlights provides high-output diffuse light. The MOBL is an area light that can contain thousands of LED lights (depending on the size). Lights are specifically engineered for high-speed packaging and bottling lines. Housing is constructed in industry aluminum extrusion to dissipate heat, while a standard T-slot channel provides ease of mounting.

### MOBL High-Output Backlight Features

- Built-in SMART driver – no external driver needed
- Continuous operation or strobe mode
- 24 V DC
- NPN and PNP strobe
- Comes in three sizes (150 x 150 mm, 300 x 150 mm, and 300 x 300 mm)



**PRODUCT FAMILY:**

Backlight  
MOBL

**SIZE:**

150 x 150  
300 x 150  
300 x 300

**COLOR:**

470, 530, 625,  
850 & WHI  
(White)

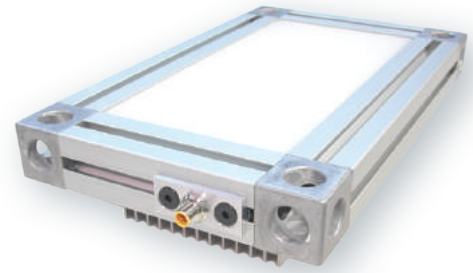

<b>AVERAGE INTENSITY RATING</b>	70,000 lux*
---------------------------------	-------------

\*Lux measurement taken at surface of MOBL

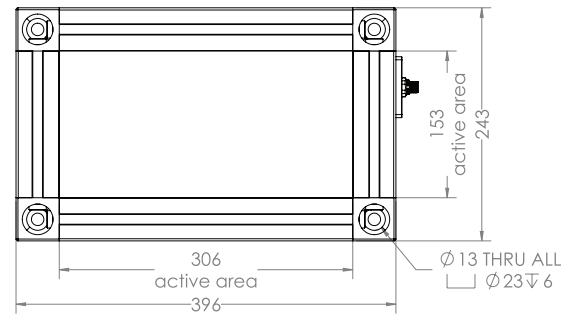
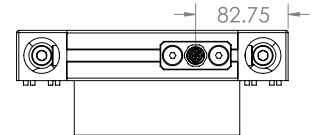

# ODMOBL High-Output Backlight with OverDrive™

## LED Backlights | High-Output

The ODMOBL series of LED backlights is the strobe-only version of the MOBL series. The ODMOBL OverDrive™ or strobe backlight is up to 10x brighter than the high-output MOBL. ODMOBL features extreme output for freezing motion on high-speed applications or when a backlight has to produce a vast amount of light to burn through a product.

### ODMOBL High-Output Backlight with OverDrive™ Features

- Similar form and features as MOBL
- Strobe-only OverDrive™ operation
- OverDrive™ units are 5x brighter than standard high-current LED lights

**PRODUCT FAMILY:**

Backlight  
ODMOBL

**SIZE:**

150 x 150  
300 x 150  
300 x 300

**COLOR:**

470, 505, 530,  
625, 850, 940  
& WHI (White)

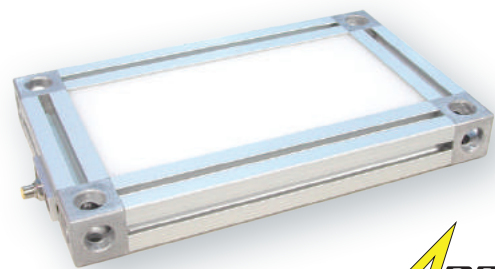

<b>AVERAGE INTENSITY RATING</b>	560,000 lux*
---------------------------------	--------------

\*Lux measurement taken at surface of ODMOBL



# SOBL Backlight

## LED Backlights

With a thin profile of only 30 mm, the SOBL Series is a dimmable area light that can contain up to thousands of LED lights (depending on the size). Housing is constructed in industry aluminum extrusion to dissipate heat, while a standard T-slot channel provides ease of mounting.

## SOBL Backlight Features

- Built-in SMART driver – no external driver needed
- NPN and PNP strobe
- Available in blue, red, IR, and white
- Analog intensity 0–10 V DC signal

**PRODUCT FAMILY:**

Backlight  
SOBL

**DIMENSIONS:**

Measured active area (mm)  
Contact SVL for more details

**COLOR:**

470, 505, 530, 625,  
850 & WHI (White)

**AVERAGE INTENSITY RATING** 30,000 lux\*

\*Lux measurement taken at surface of SOBL

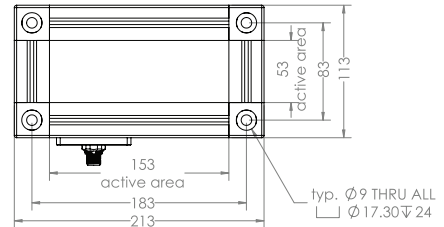

# SOBLW Backlight

## LED Backlights | Washdown

The SOBLW is a homogeneous backlight solution for harsh environments and operates in strobe or continuous mode. Comes in several sizes up to 450 mm x 300 mm (18" x 12") with larger custom items available.

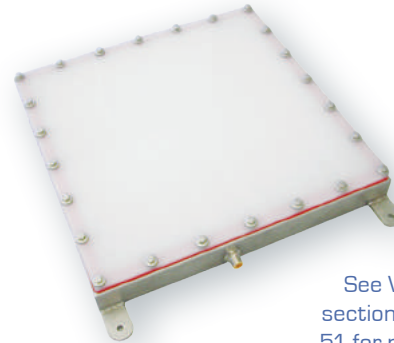

See Washdown Lights section starting on page 51 for more information.

## BACKLIGHT Application

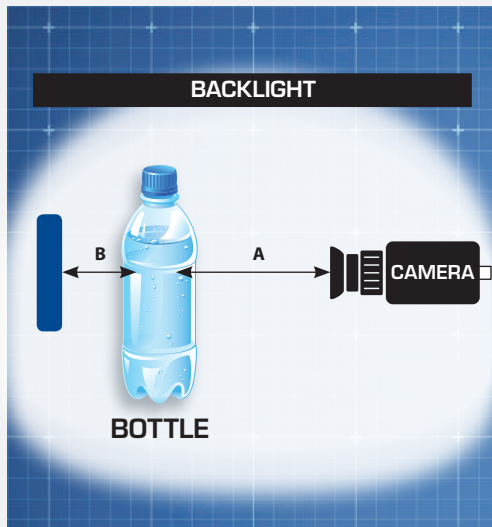

### WATER BOTTLE CAP SEAL AND FILL INSPECTION

**CLIENT REQUEST:** Inspection of plastic water bottle to verify ink-based lot and date code, presence of the bottle cap, and proper application of the bottle cap, safety seal, and fill level.

**ISSUES:** Visibility.

**Illumination:** SOBL-150x100-WHI (6 x 4) Active Area LED Backlight

**Light angle:**

**A** 19½" from the tip of the lens to the inspection area of the part

**B** 3" from the front of the light to the side of the part



**SOLUTION:** With a backlight placed behind the bottle, the inspection for the bottle cap, fill level, and safety seal are clearly visible to the camera. The system can easily pass correctly fitted caps and proper safety seals, as well as view fill levels. Improperly fitted caps, questionable safety seals, and inaccurate fill levels are failed by the vision system.

# S75 Brick Spot Light

## Brick Light

The S75 Brick Light is available in white, red, amber, blue, green, cyan, IR, and UV colors, comes with integrated constant current driver with Multi-Drive™ built-in continuous operation and strobe capabilities, and offers variable light intensity control.

### S75 Brick Spot Light Features

- Built-in SMART driver – no external driver needed
- PNP and NPN strobe
- Constant or strobed operation
- Integrated potentiometer dimming
- Remote intensity control – Analog 0–10 V DC



**PRODUCT FAMILY:**  
Brick Light  
S75

**COLOR:**  
365, 395, 470, 505, 530,  
625, 850, 940 & WHI (White)

**LENSES:\***  
W = Wide  
L = Line

*\*Narrow lens is standard*



## Light Distribution Data

### S75-XXX

WORKING DISTANCE meter (inches)	PATTERN (80%–100% measured intensity) millimeter (inches)
.5 m (19.7")	100 mm (~4") D
1 m (39.4")	200 mm (~8") D
1.5 m (59")	300 mm (~12") D
Typical output performance	
Distance = .5 m	Illumination (Lux) 9600
<i>Illumination measurement taken on White Lights – 6500 K</i>	

### S75-XXX-W

WORKING DISTANCE meter (inches)	PATTERN (80%–100% measured intensity) millimeter (inches)
.5 m (19.7")	210 mm (~4") D
1 m (39.4")	425 mm (~8") D
1.5 m (59")	650 mm (~12") D
Typical output performance	
Distance = .5 m	Illumination (Lux) 6300
<i>Illumination measurement taken on White Lights – 6500 K</i>	

## ODS75 Brick Spot Light with OverDrive™ Features



- Similar form and features as S75
- Strobe-only OverDrive™ operation
- OverDrive™ units are 5x brighter than standard high-current LED lights
- Precise current provides stable light intensity
- High-speed, fast response

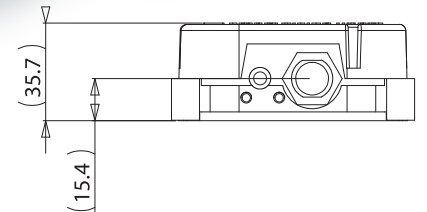
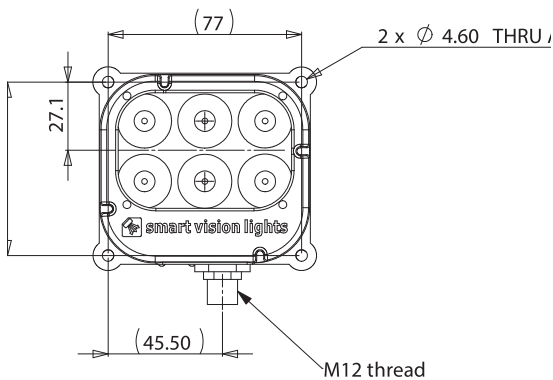

**PRODUCT FAMILY:**  
Brick Light  
ODS75

**COLOR:**  
365, 395, 470, 505, 530,  
625, 850, 940 & WHI (White)

**LENSES:\***  
W = Wide  
L = Line

*\*Narrow lens is standard*

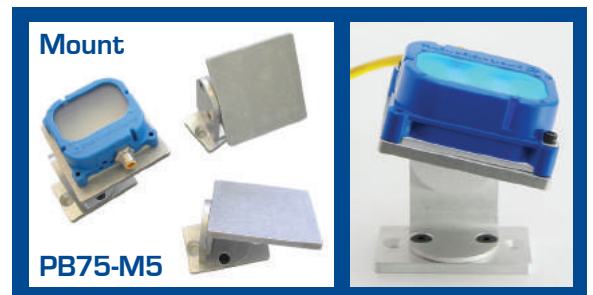

# SB75 Brick Spot Light

## Brick Light | Backlight

The SB75, the high-power backlight version of the S75, provides an intense but diffuse light pattern at any given working distance.

### SB75 Brick Spot Light Features

- Similar form and features as S75
- 2447 acrylic backlight lens
- Extremely uniform
- Active area of 66 mm x 44 mm (2.6" x 1.8")

**PRODUCT FAMILY:**

Brick Light  
SB75

**COLOR:**

470, 505, 530, 625, 850,  
940 & WHI (White)



**AVERAGE INTENSITY RATING** 60000 lux\*

\*Lux measurement taken at surface of SB75



# ODSB75 Brick Spot Light Features

- Similar form and features as SB75
- Strobe-only OverDrive™ operation
- OverDrive™ units are 5x brighter than standard high-current LED lights
- Maximum strobe time - 125 ms
- Up to 5000 strobes per second

**PRODUCT FAMILY:**

Brick Light  
ODS75

**COLOR:**

470, 505, 530, 625, 850,  
940 & WHI (White)



# SC75 Brick Spot Light

## Brick Light

Part of SVL's cost-effective Grey Series Lighting, the SC75 Brick Light does not have the ability to adjust light intensity remotely or through an integrated potentiometer.

### SC75 Brick Spot Light Features

- Similar form and features as S75
- Illumination patterns available in standard tight, wide expanded, and line
- Available in red, blue, green, IR, and white



**PRODUCT FAMILY:**

Brick Light  
SC75

**COLOR:**

470, 530, 625, 850  
& WHI (White)

**LENSES:\***

W = Wide

\*Narrow lens is standard



## Light Distribution Data

### SC75-XXX

WORKING DISTANCE meter (inches)	PATTERN (80%–100% measured intensity) millimeter (inches)
.5 m (19.7")	100mm (~4") D
1 m (39.4")	200mm (~8") D
1.5 m (59")	300mm (~12") D
Typical output performance	
Distance = .5 m	Illumination (Lux) 9600
Illumination measurement taken on White Lights – 6500 K	

### SC75-XXX-W

WORKING DISTANCE meter (inches)	PATTERN (80%–100% measured intensity) millimeter (inches)
.5 m (19.7")	210 mm (~6") D
1 m (39.4")	425 mm (~17") D
1.5 m (59")	650 mm (~22") D
Typical output performance	
Distance = .5 m	Illumination (Lux) 6300
Illumination measurement taken on White Lights – 6500 K	

# SW75 Brick Spot Light

## Brick Light | Washdown

The SW75 features a stainless-steel enclosure with sealed bolts and a waterproof connector for applications in washdown and corrosive environments.

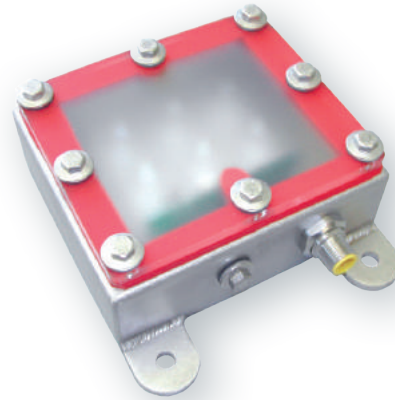

See Washdown Lights section starting on page 51 for more information.

## ODSW75 Brick Spot Light Features

- Similar form and features as SW75
- Strobe-only OverDrive™ operation
- OverDrive™ units are 5x brighter than standard high-current LED lights

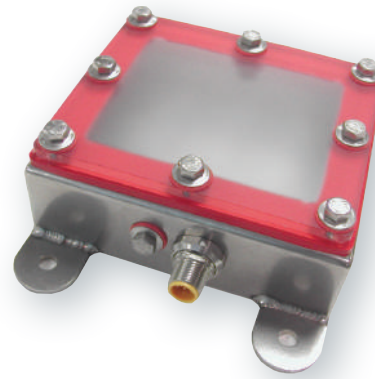

See Washdown Lights section starting on page 51 for more information.



## BRICK LIGHT Application

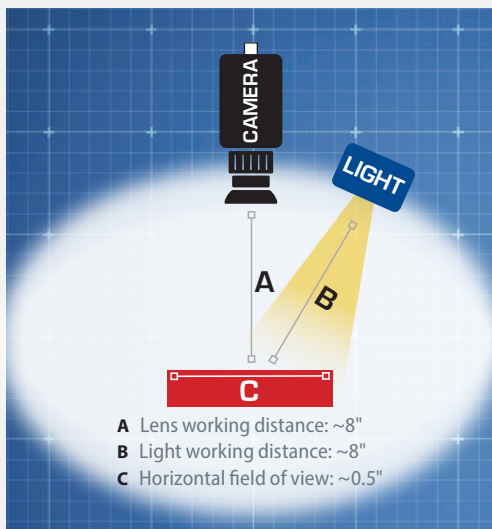

- A Lens working distance: ~8"
- B Light working distance: ~8"
- C Horizontal field of view: ~0.5"

### GASKET INSPECTION

**CLIENT REQUEST:** Inspection of automotive engine head gaskets to ensure the correct number of gaskets are present.

**ISSUES:** Due to the small size of the gasket edges, machine vision could do a far better job than human inspectors, reducing potential oil leaks and warranty work down the road.

**Illumination:** S75-505  
[75 mm Spot Light 505 nm Cyan "Brick Light"]

**Lens:** 50 mm Fujinon

**Filter:** BP505-25.5

**Extras:** Spacer Kit

### SOLUTION:

An engineering feasibility study determined that a blue brick light, placed slightly off camera-engine axis, along with a matching bandpass filter on the camera would provide edge contrast between the gaskets and metal cylinder cover. To acquire images with sufficient resolution to repeatedly identify gasket edges while using a low-cost VGA-resolution camera, our engineers opted for an 8-inch standoff between light, camera, and cylinder head, which provided a 0.5-inch camera field of view. This was more than sufficient to put several pixels across each gasket edge, increasing the vision accuracy during the gasket counting operation.

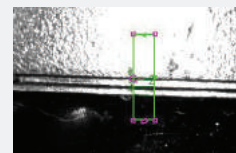

## CAMERA TO LIGHT

Smart Vision Lights' **Camera to Light** (CTL) Grey Series cable provides a directly wired connection between a single light and a camera. The CTL series is available for steady/constant or flash/strobe connections, and the cables are available in lengths of 0.3 m and 2 m, with other lengths available by request.

The CTL Grey Series cables are compatible with Smart Vision Lights' OverDrive™ lights and offer a standard M8 and M12 connection. The CTL Grey Series steady/constant camera cable offers power and ground sync and is compatible with continuous-operation lights made by Smart Vision Lights. The CTL Grey Series flash/strobe cable is compatible with Smart Vision Lights' OverDrive™ series of lights and offers power, ground, and flash sync.



## Baumer VeriSens® XC

The CTL cable provides a directly wired connection between a single light and the Baumer VeriSens® XC series camera. The Baumer VeriSens® XC series can be attached to EZ Mount Ring Lights (page 24).

- For use in external flash mode only
- Compatible with Smart Vision Lights' OverDrive™ Series lights

## Cognex Dataman®

OverDrive™ Dataman® Light Module, specifically engineered to mount and integrate seamlessly to the front of Cognex's Dataman® camera readers. It features 12 OverDrive™ LEDs available in either standard or wide projection. This light module matches the maximum scanning specs of the Dataman® cameras with strobe speeds up to 1,000 strobes per second. This light module also features the same technology and intensity output as Smart Vision Lights' OverDrive™ Series of strobe-only lights. Available in all colors and wavelengths\*.

*\*Red, red wide, and white available exclusively through Cognex.*

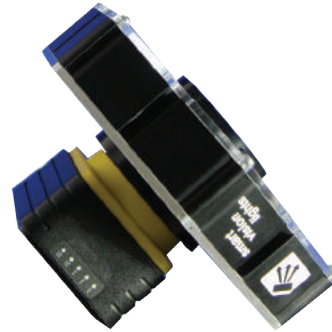

### ODDM Dataman 302

(Cognex Part #DM302-HPIA)

- Built-in Multi-Drive™ driver
- Mounts directly to Dataman 300 camera
- Supports laser aimer accessory
- Standard T-slot for mounting
- Powered directly from Dataman 300 external light control

### ODDM-302 Spacer Kit (Camera Spacer Kit)

- Mounts directly to Dataman 302 camera
- (4) 60 mm camera mounting screws
- Machined aluminum spacer bracket
- Allows use of laser aimer
- Flat acrylic cover

### ODDM Dataman 503

(Cognex Part #DM503-HPIA)

- Built-in Multi-Drive™ driver
- Mounts directly to Dataman 503 camera
- SafeStrobe technology ensures protected operation of LEDs

### ODDM Dataman L300

(Cognex Part #IVSL-YLW300)

- Works with Cognex 300 and 503 series cameras

### ODDM Dataman L300-2X

- Connects directly to Cognex camera reader
- Powered directly from Dataman camera
- 2x as many LEDs as the standard ODDM-L300

### ODDM Dataman L300-2X-LPI

- Similar form and features as ODDM Dataman L300-2X
- Installed polarizer for convenient linear polarization

### ODDM Dataman S75

(Cognex Part #IVSL-ODDM-S75)

- Works with the Cognex 300 and 503 series cameras

### ODDM Dataman S33

- Connects directly to Cognex Dataman reader
- Powered directly from Dataman external light control

## CAMERA TO LIGHT

### Cognex In-Sight®

The CTL cable provides a directly wired connection between a single light and Cognex's In-Sight® series cameras.

#### In-Sight L300

(Cognex Part #IVSL-YL300)

- Built-in Multi-Drive™ driver
- Strobe speeds up to 1,000 strobes per second

#### In-Sight S75

- Built-in Multi-Drive™ driver
- Strobe speeds up to 1,000 strobes per second

By using the cable and the adapter parts listed below, Cognex's In-Sight® series cameras can also be attached to EZ Mount Ring Lights (page 24).

- Cognex In-Sight® 5000 Camera Series
- Adapter part #DF55-46 (excludes the 5604 or 5605 series camera)
- Cognex In-Sight® 5600/5705 Camera Series
- Adapter part #DF60-46
- Cognex In-Sight® 7000 Camera Series
- Adapter part #CB-RS-IS7000



### Datalogic® A30

The CTL cable provides a directly wired connection between a single light and Datalogic® A30 series cameras. By using the cable and adapter part #DF55-46, Datalogic® A30 series cameras can be attached to EZ Mount Ring Lights (page 24).

### SICK Inspector®

The CTL cable provides a directly wired connection between a single light and SICK Inspector® series cameras. The cable features a 12-pin M12 to "Y" 12-pin + 5-pin connector and is CE and RoHS compliant. By using the cable and adapter part #CB-RS-SICK-ISP, SICK Inspector® series cameras can be attached to the following lights:

- S75 Brick Spot Light (page 10)
- L300 Linear Light (page 36)
- R80 Ring Light (page 24)
- R130 Ring Light (page 25)

### Teledyne DALSA BOA®

The CTL cable provides a directly wired connection between a single light and Teledyne DALSA's BOA® series cameras. By using the cable and adapter part #DF34.9-46, Teledyne DALSA BOA® series cameras can be attached to EZ Mount Ring Lights (page 24).

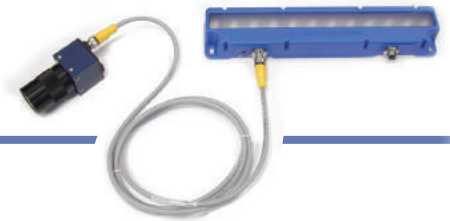

## CONTROLLER TO LIGHT

Smart Vision Lights' Controller to Light Series is designed to work with Keyence, Gardasoft standard and triniti™ external LED light controllers, instead of our universal internal OverDrive and Multi-Drive™ drivers. Smart Vision Lights has modified four of its most popular models — the S75 brick, L300 linear, R80 ring, and R130 ring lights — for these third-party external LED controllers.

### Controller to Light base model features:

- S75 brick spot light with 6 1mm<sup>2</sup> die high-current LEDs
- L300 linear light with 12 1mm<sup>2</sup> die high-current LEDs
- R80 ring light with 12 1mm<sup>2</sup> die high-current LEDs
- R130 ring light with 8 1mm<sup>2</sup> die high-current LEDs

### Controller to Light additional features:

- Direct Connect to Keyence, Gardasoft, and triniti controllers
- Standard narrow lenses included; wide available
- Heat is dissipated through the aluminum back plate, which allows these lights to be run at a higher current and greater intensity
- Available wavelength range from 365 nm UV to 940 nm IR

### Keyence

Smart Vision Lights' KEY Series lights connect directly to the Keyence controller. These lights feature an industry-standard 5-pin M12 connector.

- Models: KEY-S75, KEY-L300, KEY-R80, KEY-R130

### Gardasoft

The GRD Series lights are able to connect directly to the controller. These lights feature an industry-standard 5-pin M12 connector.

- Models: GRD-S75, GRD-L300, GRD-R80, GRD-R130

### triniti

Smart Vision Lights partnered with Gardasoft Vision to provide LED lighting solutions enabled with Gardasoft's system-enabling triniti™ technology. Triniti technology provides expert control, operational intelligence, and full integration of machine vision lighting within a plug-and-play environment. The TRI Series lights are able to connect directly to the triniti controller. These lights feature an industry-standard 5-pin M12 connector.

- Models: TRI-S75, TRI-L300, TRI-R80, TRI-R130

# Custom Lights

Smart Vision Lights' engineering department has helped thousands of clients develop custom lights for volume applications. Using the latest optical modeling and simulation software, our engineers help customers refine the specifications of their application as it relates to illumination. Once the specification is complete, we look at each component to make sure the design meets performance requirements while also guaranteeing design for manufacturability.

As part of this process, we consider:

- Size
- Color
- Output requirements
- Optics and lensing
- Enclosure quality (washdown or standard industrial enclosure)
- Cooling methods if necessary for high-power models
- Specialty connectors, cabling, adapters, and mounts

Smart Vision Lights also conducts testing to IEC 62471 standards as well as electrical testing standards to comply with all ANSI and CE marking requirements and operator safety.

## LW400 (Washdown Linear Light)

**PROBLEM:** A customer needed a fully FDA-compliant linear light for food preparation areas that could withstand washdown environments, including water and corrosive materials – all in the smallest footprint possible.

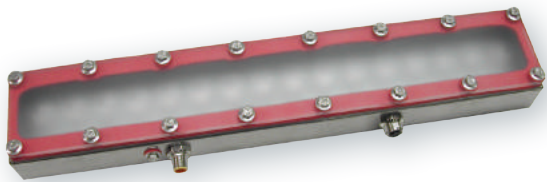

- IP69K-rated stainless steel housing
- Designed to operate in food applications
- 5-pin M12 quick disconnect
- Option of connecting lights together
- Built-in driver – no external wiring to a driver

**SOLUTION:** Smart Vision Lights' engineers evaluated the application requirements and developed the LW400 version of the company's L300 and LE300 linear lights. The LW400 series features a 100% waterproof stainless-steel enclosure specially designed for food-industry and washdown environments where water and corrosive materials are present. All circuitry is enclosed in an epoxy potting compound to further protect the light from dust, debris, and all other contaminants. The LW400 array utilizes 16 high-intensity LEDs and is the longest light in the Connect a Light series. It also features an integrated constant-current driver built into the light. Built-in driver technology, pioneered by Smart Vision Lights during the company's creation, minimizes wiring and space requirements.

- PNP and NPN strobe input
- Continuous operation or strobe mode
- Dimmable via built in potentiometer
- Analog intensity 0–10 V DC signal
- 16 1mm<sup>2</sup> die high current LEDs

## MOBL (Backlight)

**PROBLEM:** A customer needed a light that could create virtually any color to provide maximum contrast for imaging object outlines and surfaces as well as complement products of any color for defect inspection, a common need among flexible manufacturing processes and mixed-product production lines.

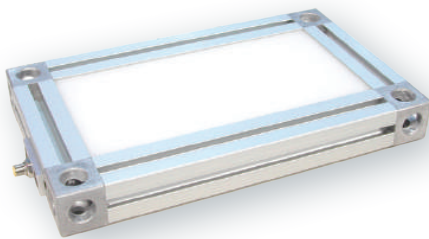

- Larger 45 mm Industrial Extrusion
- Most intense and diffuse backlight available
- Red, Green, and Blue wavelengths
- 12-pin M12 connector
- Heatsinking for use in hotter environments

**SOLUTION:** After carefully evaluating the application and a wide selection of sample product photos and setting a variety of illumination solutions in our in-house lighting laboratory, SVL engineers designed a MOBL series backlight that could produce red, green, and blue light, as well as mix the colors based on intensity, creating virtually any color of the visible spectrum.

The MOBL series features three independent and fully controllable colors; red, green, and blue. The three LED colors are fully controllable in that any color can be replicated by modulating each of the three primary colors. Additional heat sinking allows the MOBL backlight to remain cool at maximum intensity, even in above-average ambient temperatures, while the 12-pin M12 connector with flying leads and the 45 mm industrial extrusion housing allow for ease of installation and a secure mounting option.

# DFL460 Dark Field Light

## Curved Linear Connect a Light

The DFL460 array uses 16 high-intensity LEDs to provide a round 90° light illumination. The light has the ability to daisy-chain up to four lights together through the use of the 5-pin 5PM12-J1000 cable and mounting hardware. Available in standard narrow, wide, and line optics with options for all standard and some custom wavelengths.

### DFL460 Dark Field Light Features

- Built in SMART driver - no external driver needed
- Ability to wrap light around curved surfaces
- Connect up to 4 lights together
- Continuous operation or strobe mode
- PNP and NPN strobe input
- Analog intensity via 0-10 V DC signal
- Lenses create thin-focused uniform line of light

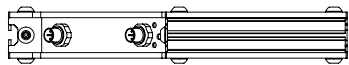

**PRODUCT FAMILY:**

Dark Field Light  
DFL460

**COLOR:**

470, 505, 530, 625, 850,  
940 & WHI (White)

**LENSES:\***

N = Narrow  
W = Wide

*\*Line lens is standard*

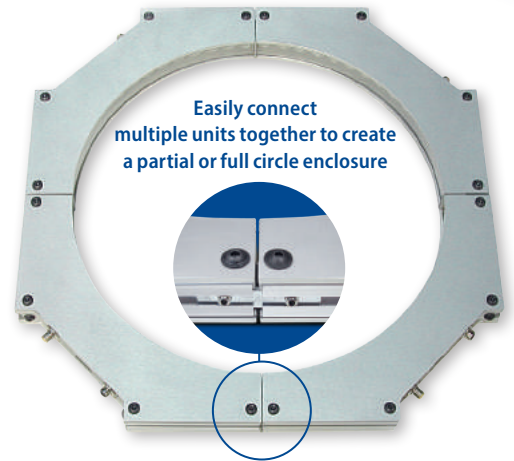

AVERAGE INTENSITY RATING	Wide lens	24,000 lux*
	Narrow lens	67,000 lux*

*\*Lux measurement taken at .150 mm from center*



# DFLB Diffused Light

## Curved Linear Connect a Light | Diffused Light

The DFLB is a very diffused version of the DFL460 Dark Field Light and has similar form and features. Connecting four of the DFLB lights together will create a diffused ring light.

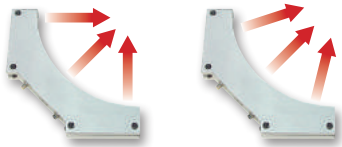

Light distribution options

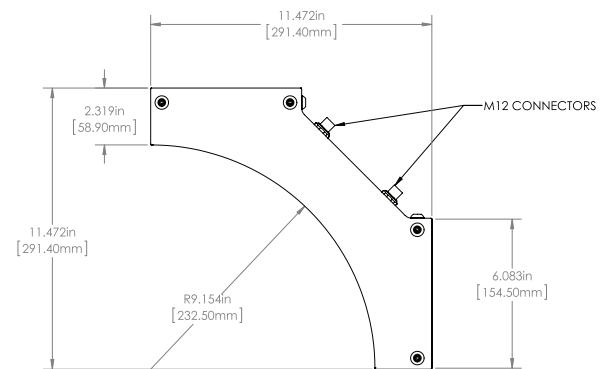

**PRODUCT FAMILY:**

Dark Field Light  
DFLB

**COLOR:**

470, 505, 530, 625, 850,  
940 & WHI (White)

**LENSES:\***

N = Narrow  
W = Wide

*\*Line lens is standard*





# DFL12/DFL24 Dark Field Light

## Adjustable Dark Field Light

The Adjustable Dark Field Light acts as a mount to daisy-chain linear lights together in a square pattern. Users can attach up to four linear lights. Light features a 360° illumination field with two available options: DFL12 (300 mm) and DFL24 (600 mm).

## DFL12/DFL24 Dark Field Light Features

- Adjustable lights on aluminum extrusion
- 300 x 300 mm and 600 x 600 mm area
- Lights can be strobed together or separate
- PNP and NPN strobe input
- Continuous operation or strobe mode
- Dimmable via built-in potentiometer
- Analog intensity 0-10 V DC signal
- Standard optics provide tight light pattern



**PRODUCT FAMILY:**

Dark Field Light  
DFL300/600

**COLOR:**

470, 505, 530, 625, 850, 940  
& WHI (White)

**LENSES:\***

N = Narrow  
W = Wide

*\*Line lens is standard*

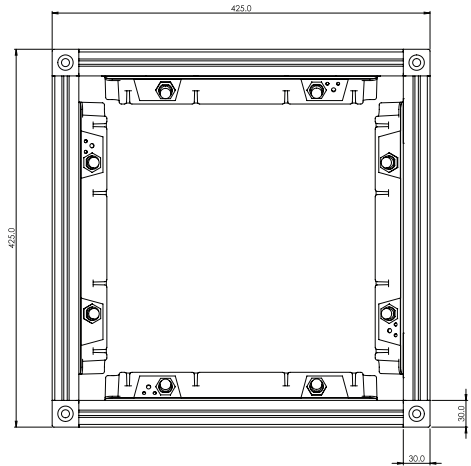
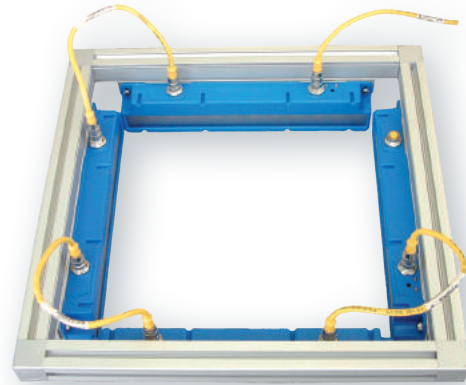

## Cast iron ring (DFL 460)

Dark field lights are used to add contrast to images of parts with raised or stamped features. Off-axis illumination highlights the vertical sides of the embossed element, providing clear edge contrast between the target feature and the surrounding object. The **DFL460 dark field light** helped our customer locate and inspect an arrow stamped onto a metal part.

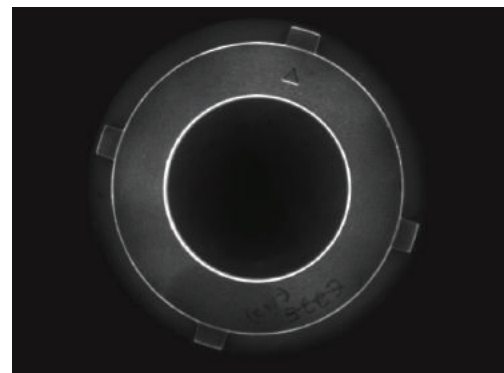

Cast iron ring

# DLP Front Light Series

## Diffuse Ring Light Panels

The DLP Front Light Series of dimmable lights is highly versatile with many custom sizes available. The series offers backlit LEDs for a more intense and highly diffuse lighting option. With its built-in driver, the DLP requires no external wiring, and its narrow depth of 30 mm allows for mounting in tight locations. The DLP Series of front lights offer a 53 mm camera hole in the center for the 190 x 190 mm and a 78 mm hole for the 300 x 300 mm and larger sizes for ease of viewing.



AVERAGE INTENSITY RATING	190 x 190	44,000 lux*
	300 x 300	32,000 lux*
	450 x 450	32,000 lux*
	600 x 600	32,000 lux*

\*Lux measurement taken at surface of DLP

### DLP Front Light Series Features

- 30 mm industrial extrusion
- Built-in SMART driver – no external driver needed
- PNP and NPN strobe input
- Continuous operation or strobe mode
- Analog intensity 0–10 V DC signal
- Offered in white, red, green, blue, and IR



**PRODUCT FAMILY:**  
Diffuse Ring Light  
DLP

**SIZE:**  
190 x 190  
300 x 300  
450 x 450  
600 x 600

**COLOR:**  
470, 530, 625,  
850 & WHI  
(White)

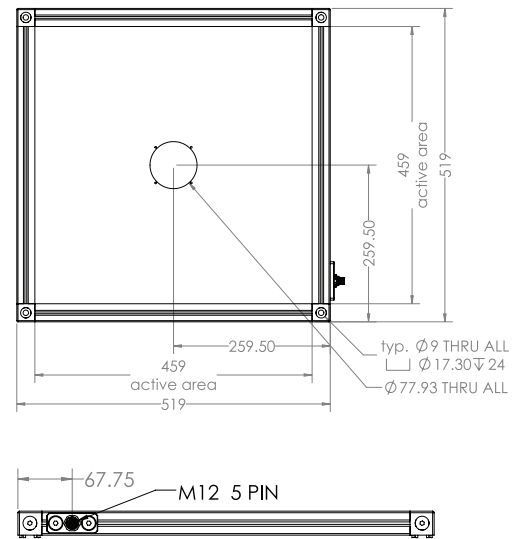

# DLPW Front Light Series

## Diffuse Ring Light Panels | Washdown

The DLPW Front Light Washdown Series is specially designed for food industry and washdown environments where water and corrosive materials are present. The light offers a 65 mm camera hole in the center. Active area measurements include 190 mm x 190 mm, 300 mm x 300 mm, and 600 mm x 600 mm.

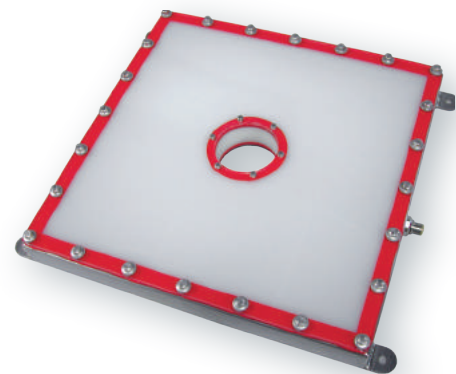

See Washdown Lights section starting on page 51 for more information.

# LLPX-H Diffuse Large Light Panel Series

## Diffuse Large Light Panel

The LLPX-H Series is Smart Vision Lights' second generation of LLPX-H light panels that allows for more intensity with the same familiar ease of mounting. With its new optically clear internal light dispersion grid and matte white-finished backing plate, more light is reflected up and out through the diffusion acrylic. Custom hole placement and two hole-size options add to its versatility. The integrated Multi-Drive™ constant current driver operates continuously or in OverDrive™ strobe mode.

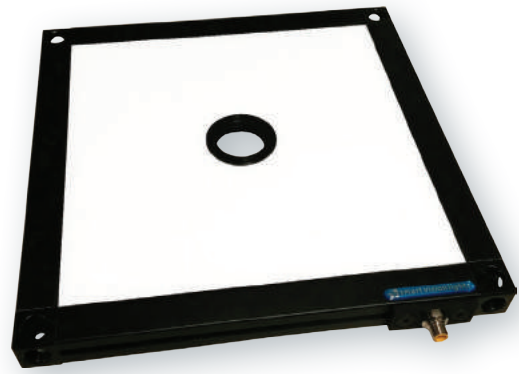

<b>AVERAGE INTENSITY RATING</b>	8000 lux*	OverDrive™ 40,000 lux*
---------------------------------	-----------	------------------------

\*Lux measurement taken at surface of LLPX-H

**Customize this light:** Up to 3 wavelengths can be included in a single light.

## LLPX-H Diffuse Large Light Features

- 30 mm frame profile
- Built-in SMART driver – no external driver needed
- M12 quick disconnect
- Edge-lit LED panel
- Custom sizes/multiple hole placement options
- Continuous operation or strobe mode



<b>PRODUCT FAMILY:</b> Diffuse Ring Light LLPX-H	<b>CENTER HOLE SIZE:</b> H45 = 45 mm H65 = 65 mm*	<b>SIZE*:</b> 306 x 306 459 x 459	<b>COLOR:</b> 470, 530, 625, 850 & WHI (White)
	* Standard	* Custom sizes upon request	* Other colors upon request

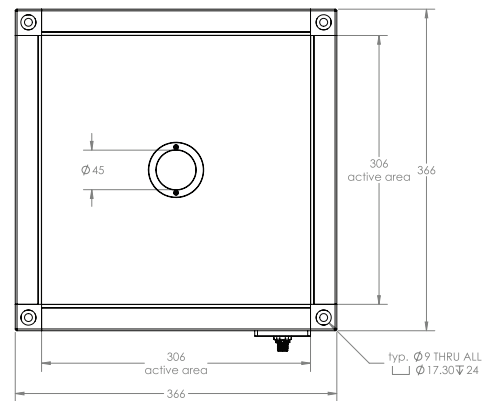

CAD drawings are 306 x 306 mm versions of LLPX-H.

## DOME LIGHT Application



### TABBED PART INSPECTION

**CLIENT REQUEST:** Inspect metal components assembled using folded tabs. System's primary goal is to check for tab placement and verify assembly.

**ISSUES:** Highly reflective components posed unique challenge to inspection of hole diameter and placements due to need for sufficient contrast without creating hot spots on metal surfaces that would decrease inspection efficiency.

**Vision system:** Cognex InSight 1403

**Illumination:** DLP300x300-625 Flat Dome Light

**Lens:** 12.5 mm Fujinon

**Filter:** Red Light Bandpass Filter

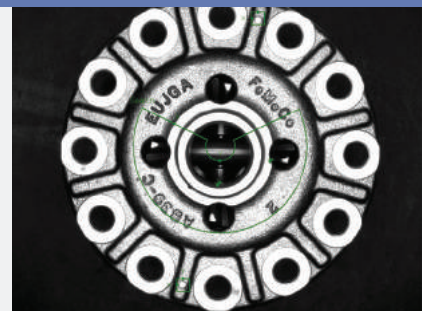

**SOLUTION:** An engineering feasibility study determined that a DLP300x300-625 red flat dome light — with matching bandpass filter to allow only the red light to pass back through to the camera — would provide the best contrast images of highly reflective parts, thanks to the highly diffuse bright illumination provided by the DLP series light. By using a Cognex InSight smart camera running PatMax geometric pattern-matching software algorithms, the solution could quickly conduct multiple spatial measurements on key product features with a high degree of reliability.

# DDL100 Dome Light

## Dome Lights

The DDL100 Dome Light reads code and imperfections on rounded or highly reflective products with an even, uniform, and repeatable light intensity. The series features Smart Vision Lights' built-in Multi-Drive™ controller, which allows the user to run the product in continuous operation or pulse/strobe the light at the LED manufacturer's maximum allowed intensity by simply setting the product parameters. The DDL100 Series is a diffuse 4" dome light featuring 20 LEDs and a semireflective white dome.

## DDL100 Dome Light Features

- Closed-in cover
- Built-in SMART driver - no external driver needed
- NPN or PNP signal options
- Industry-standard 5-pin M12 disconnect
- Analog intensity 0-10 V DC signal
- 100 mm dome diameter
- 25 mm camera viewing hole
- Continuous operation or strobe mode
- Easy mounting with 6 T-slots
- Available in white, blue, green, and red

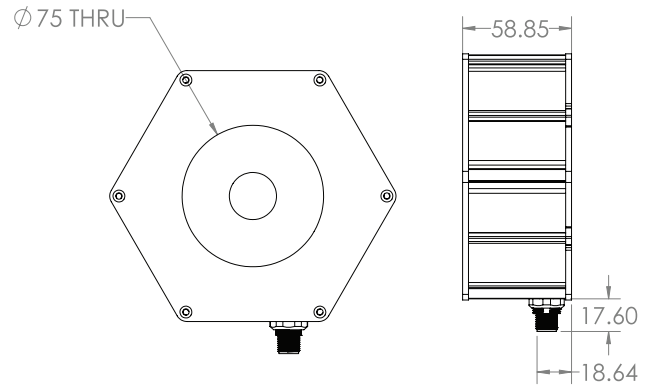
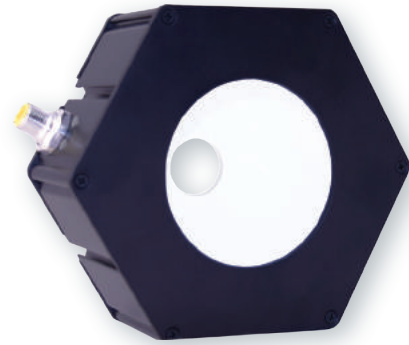

**PRODUCT FAMILY:**

Dome Light  
DDL100

**COLOR:**

470, 530, 625  
& WHI (White)



# BKT0007

## Dome Light Mount

BKT0007 is the camera-to-DDL mounting system (all sizes).

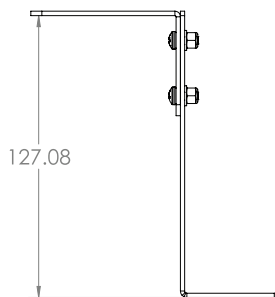
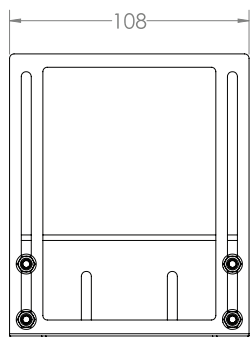
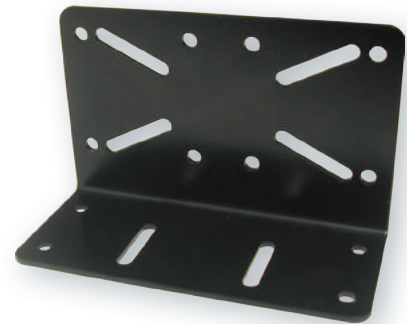

MAX HEIGHT

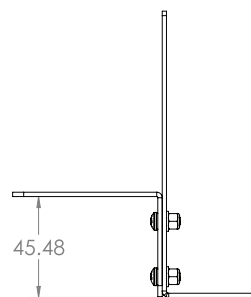

MIN HEIGHT

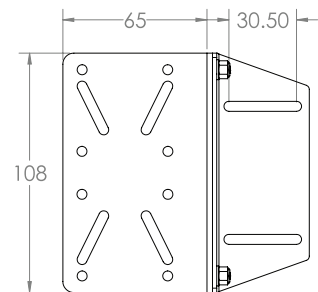

108

# DDL150 Dome Light

## Dome Lights

The DDL150 Series is a diffuse 6" dome light.

### DDL150 Dome Light Features

- Similar form and features as DDL100
- 150 mm dome diameter
- 30 mm camera viewing hole
- Easy mounting with 9 T-slots



**PRODUCT FAMILY:**  
Dome Light  
DDL150

**COLOR:**  
470, 530, 625  
& WHI (White)

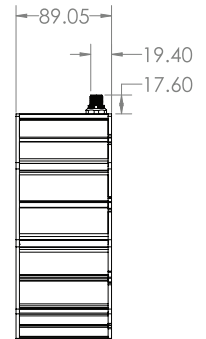
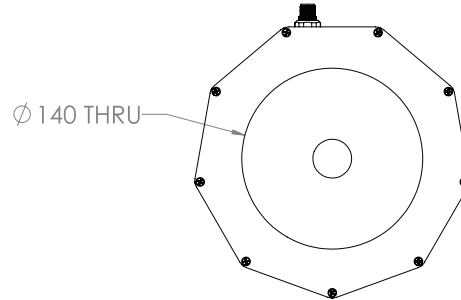
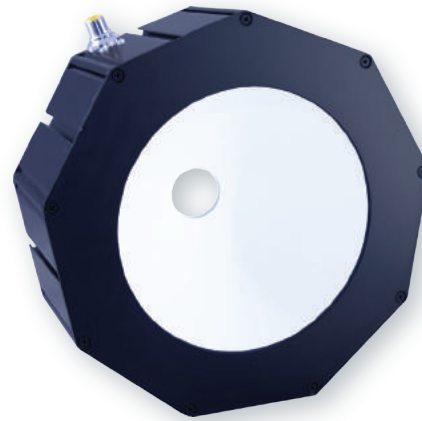

# DDL250 Dome Light

## Dome Lights

The DDL250 Series is a diffuse 10" dome light.

### DDL250 Dome Light Features

- Similar form and features as DDL100
- 250 mm dome diameter
- 30 mm camera viewing hole
- Easy mounting with 14 T-slots



**PRODUCT FAMILY:**  
Dome Light  
DDL250

**COLOR:**  
470, 530, 625  
& WHI (White)

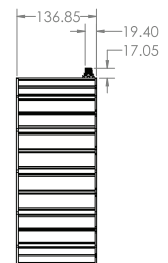
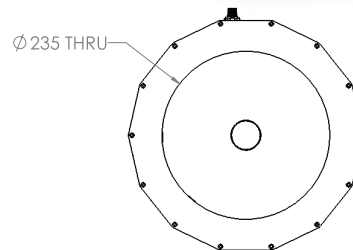
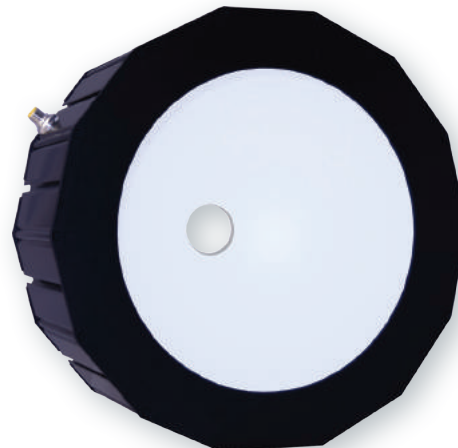

## Dome Light Accessories

The DDL Series offers a specially designed camera mounting bracket and an optional right angle bracket. Multiple adjustment points means maximum mounting versatility between camera manufacturers. Mounting hardware included.

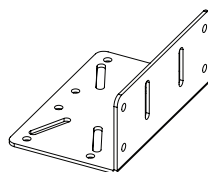

**BKT-0004**

Right Angle Bracket



**LHF300-BKT**

Mounting Bracket

# TL305 Diffuse On & Off Axis Light



## “Blister Pack” Light

The TL305 Series was designed as a pharmaceutical blister-pack inspection light with a built-in individual on-axis and off-axis intensity control lighting system. Exceptional uniformity and an intense output, combined with a “cloudy day illuminator” design, make the TL300 Series a perfect lighting solution for blister-pack inspection, solder joint inspection, or any inspection of products with a highly reflective finish.

## TL305 Light Features

- 5-pin M12 quick disconnect
- Built-in SMART driver – no external driver needed
- Simple 24 V DC and GND hookup
- Continuous operation or strobe mode
- Individual intensity control via two built-in potentiometers
- Analog intensity 0–10 V DC signal

**PRODUCT FAMILY:**  
Blister Pack Light  
TL305

**COLOR:**  
WHI (White)

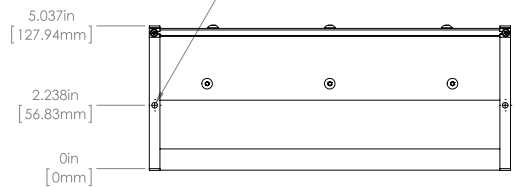

\*Intensity control module Included

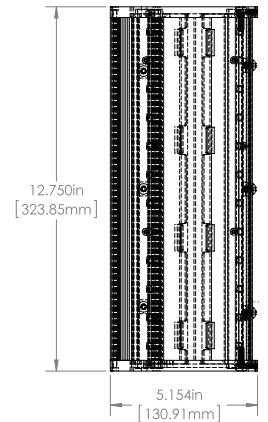

## LINEAR LIGHT Application

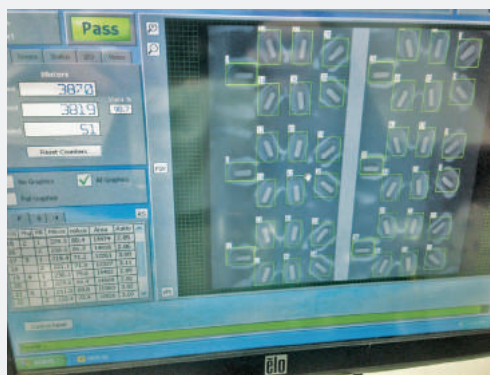

Illumination: TL305 Diffuse On & Off Axis Light

**CLIENT REQUEST:** A large contract pharmaceutical packager faced the challenge of how to light multiple inspection systems for a wide variety of highly reflective pharmaceutical and medical packages.

## PHARMACEUTICAL BLISTER PACK INSPECTION

**ISSUES:** The company’s products come in a variety of colors and formats, such as two-color capsule, single-color capsule, transparent gel capsules, semitransparent gel capsules, round tablets, oval tablets, and more. These products are packaged on multiple blister packaging lines that handle myriad package formats such as flat foil, pocketed foil, lined foil, cardboard, and paper. The company was struggling with a variety of different lights from various manufacturers to find a “one light fits all” solution that would provide a completely even light approach from all axes for the packaging line scan cameras.



**SOLUTION:** The TL305 Diffuse On & Off Axis Light delivers an intense amount of light from an on-axis architecture supplemented by an array of off-axis illumination. The light is designed to supplement direct lighting with matching intensity of a diffused architecture. The TL305 delivers reduced “hot spots” and glare, better imagery on gel caps, and increased color response of the camera. Separate intensity controls for each axis of light has allowed the customer to implement numerous cameras for inspection on multiple processing lines for products including clear, brown, and opaque containers, and products varying in formats, colors, and hues.

# DADL75-RGB

## Dual-Axis RGB LED Light

The DADL75 Series was designed as a multicolor inspection light with built-in individual on-axis and off-axis intensity control. Its exceptional uniformity and an intense output design make the DADL75 Series a perfect lighting solution for applications that require variable intensities with multiple color options or any product inspection process involving a highly reflective finish.

### DADL75-RGB Features

- 12-pin M12 quick disconnect
- Built-in SMART drive – no external driver needed
- NPN or PNP signal options
- 24 V DC and GND hookup
- Continuous operation or strobe mode
- Variable intensity control on each RGB channel
- RGB color selectability – 3 analog channels per axis
- Both on- and off-axis illumination options
- Controller suitable for testing and lab setup

**PRODUCT FAMILY:**  
RGB Dome Light  
DADL75-RGB

**COLOR:**  
3-Channel  
R+G+B

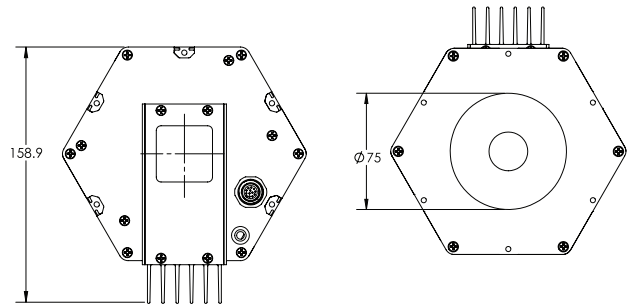
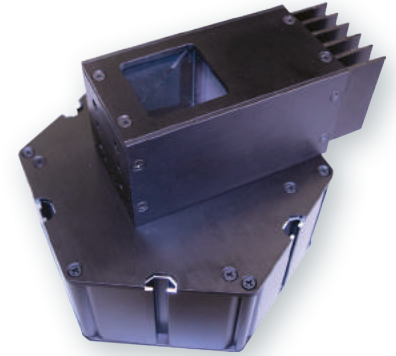
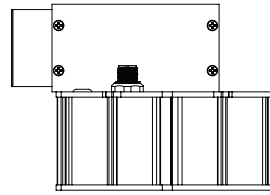
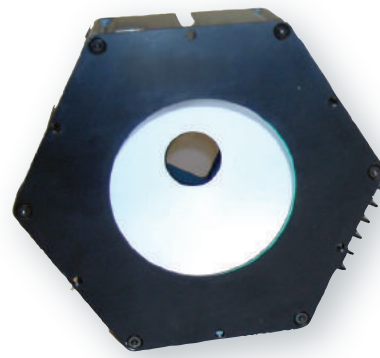

# DADL75-POT

## Dual-Axis RGB LED Light Controller

Digital readout dimming controller with dial and connecting cable to light



# R80 EZ Mount Ring Light

## EZ Mount Ring Light

The EZ Mount Ring Light is a high-output LED light in an all-metal housing that uses industry standard T-slots for ease of mounting. A standard 42 mm inner-hole diameter allows for use with nearly all camera systems with available step-up and step-down conversion kit adapters. Series includes an integrated constant current driver with a built-in strobe input with option for PNP or NPN trigger control. Intensity can be controlled via 0-10 V remote analog signal or integrated manual potentiometer. The EZ Mount Ring Light can be quickly and easily adapted to any vision system with any of four standard mounting options.

## R80 EZ Mount Ring Light Features

- Ring light mounts directly to all models of CCTV lenses
- Mounting options include front, back, and small camera configurations
- Adapter rings for all lens sizes
- Can be mounted by T-slot with T-nut
- Built-in SMART driver—no external driver needed
- Industrial standard M12-style quick disconnect
- Available in white, red, blue, green, cyan, IR, and UV
- PNP and NPN strobe input

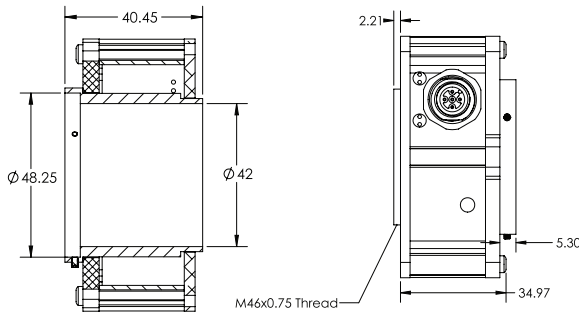

<b>PRODUCT FAMILY:</b> Ring Light R80	<b>COLOR:</b> 365, 395, 470, 505, 530, 625, 850, 940 & WHI (White)	<b>LENSES:*</b> N = Narrow
---	--	-------------------------------

\*Wide lens is standard

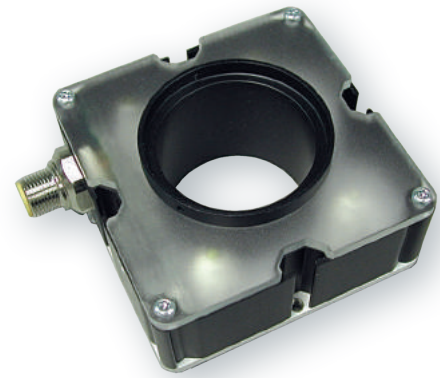

## Light Distribution Data

### R80-XXX

WORKING DISTANCE meter (inches)	PATTERN (80%–100% measured intensity) millimeter (inches)
.25 m (10")	90 mm (3.5") D
.5 m (20")	180 mm (7") D
.75 m (30")	270 mm (10.5") D
1 m (40")	360 mm (14") D
Typical output performance	
Distance = .5 m	3600 OverDrive™ 18,000
Illumination measurement taken on White Lights – 6500 K	

### R80-XXX-N

WORKING DISTANCE meter (inches)	PATTERN (80%–100% measured intensity) millimeter (inches)
.25 m (10")	80 mm (~3.1") D
.5 m (20")	90 mm (~3.54") D
.75 m (30")	135 mm (~5.3") D
1 m (40")	190 mm (~7.5") D
Typical output performance	
Distance = .5 m	9200 OverDrive™ 37,000
Illumination measurement taken on White Lights – 6500 K	

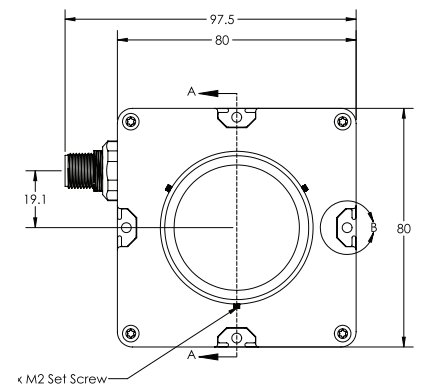

## ODR80 EZ Mount Ring Light with OverDrive™ Features



- Similar form and features as R80
- Strobe-only OverDrive™ operation
- OverDrive™ units are 5x brighter than standard high-current LED lights

<b>PRODUCT FAMILY:</b> Ring Light ODR80	<b>COLOR:</b> 365, 395, 470, 505, 530, 625, 850, 940 & WHI (White)	<b>LENSES:*</b> N = Narrow
---	--	-------------------------------

\*Wide lens is standard





# R130 EZ Mount Ring Light

## EZ Mount Ring Light

### R130 EZ Mount Ring Light Features

- Similar form and features as R80

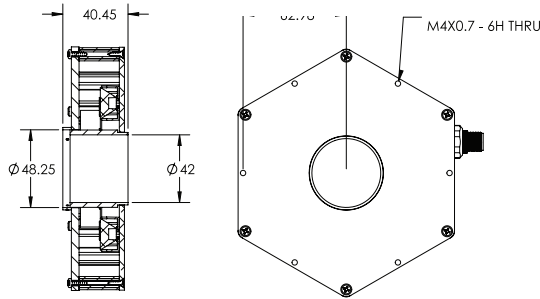

**PRODUCT FAMILY:**

Ring Light  
R130

**COLOR:**

365, 395, 470, 505, 530,  
625, 850, 940 & WHI (White)

**LENSES:\***

N = Narrow

*\*Wide lens is standard*

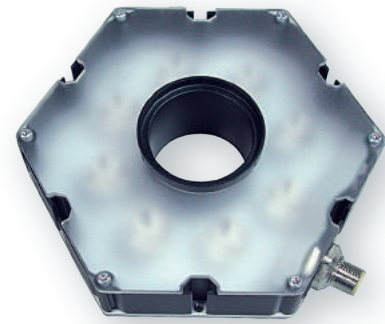

## Light Distribution Data

### R130-XXX

WORKING DISTANCE meter (inches)	PATTERN (80%–100% measured intensity) millimeter (inches)
.25 m (10")	150 mm (~6") D
.5 m (20")	250 mm (~10") D
.75 m (30")	350 mm (~14") D
1 m (40")	450 mm (~18") D
Typical output performance	
Distance = .5 m	5000   OverDrive™ 25,000
<i>Illumination measurement taken on White Lights – 6500 K</i>	

### R130-XXX-N

WORKING DISTANCE meter (inches)	PATTERN (80%–100% measured intensity) millimeter (inches)
.25 m (10")	90 mm (~3.5") D
.5 m (20")	120 mm (~4.7") D
.75 m (30")	160 mm (~6.3") D
1 m (40")	220 mm (~8.6") D
Typical output performance	
Distance = .5 m	14,000   OverDrive™ 95,000
<i>Illumination measurement taken on White Lights – 6500 K</i>	

## ODR130 EZ Mount Ring Light with OverDrive™ Features



- Similar form and features as R130
- Strobe-only OverDrive™ operation
- OverDrive™ units are 5x brighter than standard high-current LED lights

**PRODUCT FAMILY:**

Ring Light  
ODR130

**COLOR:**

365, 395, 470, 505, 530,  
625, 850, 940 & WHI (White)

**LENSES:\***

N = Narrow

*\*Wide lens is standard*

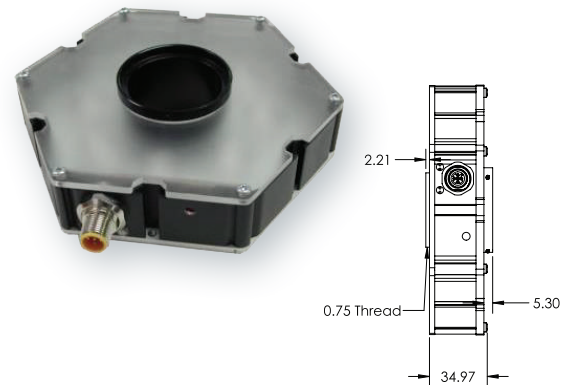

## ODR130-16 EZ Mount Ring Light with OverDrive™ Features



- Similar form and features as ODR130
- 16 high-current LEDs

**PRODUCT FAMILY:**

Ring Light  
ODR130-16

**COLOR:**

365, 395, 470, 505, 530,  
625, 850, 940 & WHI (White)

**LENSES:\***

N = Narrow

*\*Wide lens is standard*

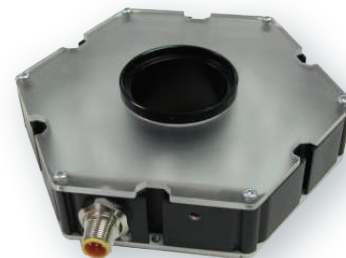

# RC130 EZ Mount Ring Light

## EZ Mount Ring Light with Focused Wide Lenses

The RC130 was designed to produce a large uniform/homogeneous light pattern. To achieve this, the RC130 contains special lenses for creating this near collimated light pattern. Optics include a focused uniform lens for wide vision.

### RC130 EZ Mount Ring Light Features

- Similar form and features as R130

**PRODUCT FAMILY:**

Ring Light  
RC130

**COLOR:**

365, 395, 470, 505, 530,  
625, 850, 940 & WHI (White)

*\*Wide lens is standard*



## Light Distribution Data

RC130-XXX

WORKING DISTANCE meter (inches)	PATTERN (80%–100% measured intensity) millimeter (inches)
1 m (39")	560 mm (22.1") D
2 m (79")	1200 mm (47.2") D
3 m (118")	1850 mm (72.8") D
<b>Typical output performance</b>	
Distance = 1 m	552
<i>Illumination measurement taken on White Lights – 6500 K</i>	

# RCC130 EZ Mount Ring Light

## EZ Mount Ring Light with Focused Narrow Lenses

The RCC130 was designed to produce a narrow uniform/homogeneous light pattern. Optics include a tightly focused uniform lens for narrow vision.

### RCC130 EZ Mount Ring Light Features

- Similar form and features as R130

**PRODUCT FAMILY:**

Ring Light  
RCC130

**COLOR:**

365, 395, 470, 505, 530,  
625, 850, 940 & WHI (White)

*\*Narrow lens is standard*

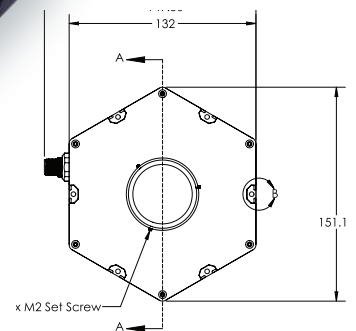
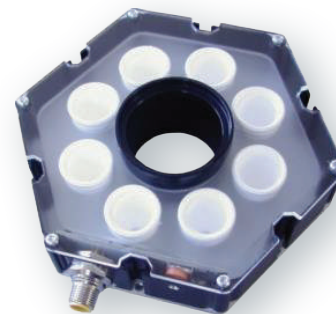

## Light Distribution Data

RCC130-XXX

WORKING DISTANCE meter (inches)	PATTERN (80%–100% measured intensity) millimeter (inches)
1 m (39")	98 mm (3.86") D
2 m (79")	180 mm (7.09") D
3 m (118")	310 mm (12.2") D
<b>Typical output performance</b>	
Distance = 1 m	12,480
<i>Illumination measurement taken on White Lights – 6500 K</i>	

# RD80 EZ Mount Ring Light

## EZ Mount Diffuse Ring Light

The RD80 provides a diffuse lens that breaks up light into a more diffuse and even pattern, making it ideal for inspecting metallic or semi-metallic materials.

### RD80 EZ Mount Ring Light Features

- Similar form and features as R80

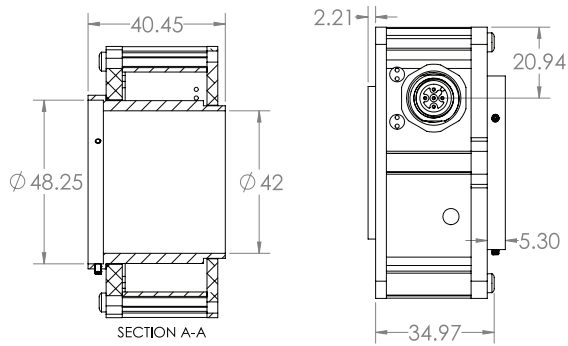

**PRODUCT FAMILY:**  
Ring Light  
RD80

**COLOR:**  
470, 505, 530, 625, 850,  
940 & WHI (White)

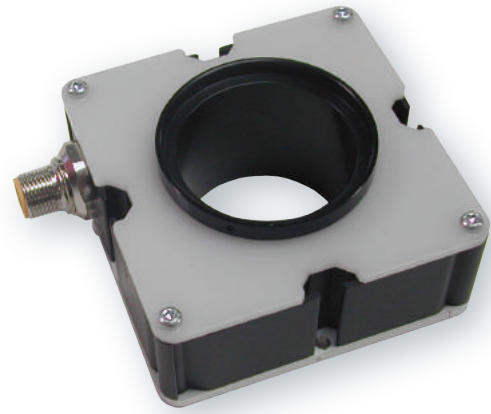

<b>AVERAGE INTENSITY RATING</b>	8000 lux
---------------------------------	----------

The RD80 offers a diffuse light pattern at a defined working distance of greater than ~10'.

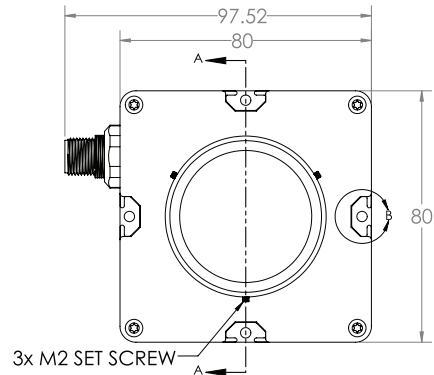
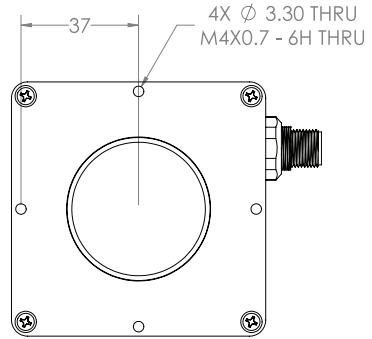

## ODRD80 EZ Mount Ring Light with OverDrive™ Features



- Similar form and features as RD80
- Strobe-only OverDrive™ operation
- OverDrive™ units are 5x brighter than standard high-current LED lights

**PRODUCT FAMILY:**  
Ring Light  
ODRD80

**COLOR:**  
470, 505, 530, 625, 850,  
940 & WHI (White)

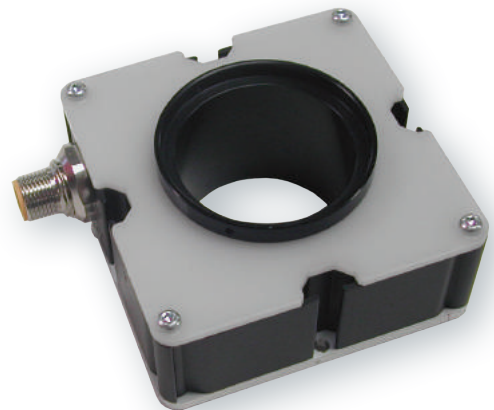

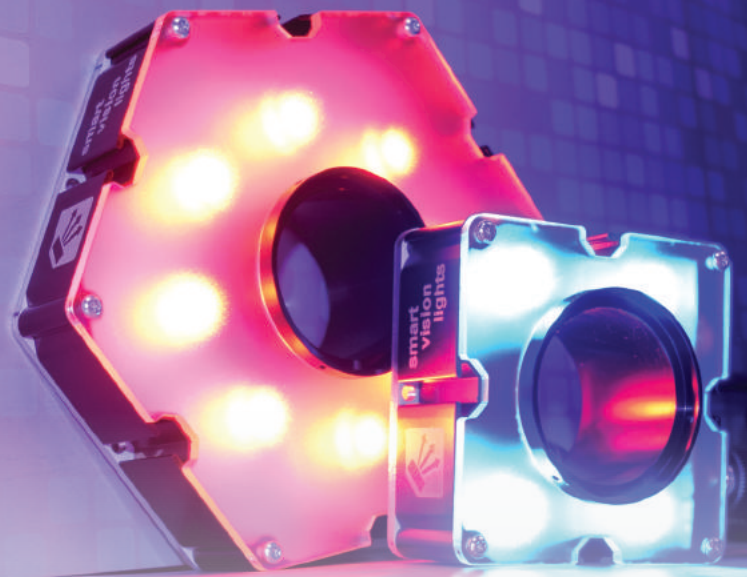

## All EZ Mount LED Ring Lights Mount Directly to a Camera Lens

The EZ Mount LED Ring Light can be quickly and easily adapted to any vision system with any of the four standard mounting options provided with each unit. First, there is a standard M46 thread protruding from the back of the EZ Mount LED Ring Light. Using readily available step-up or step-down rings, it can be mounted directly to the threads found on the front end of most lenses.

Second is the ability to mount the lens at the front end of the EZ Mount LED Ring Light. Once again, an off-the-shelf M46 step ring can be used to adapt lenses with M43 or smaller filter-mounting threads. A flange at the front end of the EZ Mount LED Ring Light holds the step ring with three set screws, and the camera lens is inserted through the center of the EZ Mount LED Ring Light and threaded onto the step ring. In those few cases in which the lens' locking thumbscrews may prevent the lens from fitting through the

center of the EZ Mount LED Ring Light, extra low-profile replacement set screws are included, allowing the protruding thumbscrews to be removed. Third is a T-slot on all sides. Standard industrial T-nuts can be dropped into the slot for mounting. The fourth way to mount the light is using the threaded M4 holes on the back plate of the light.

The EZ Mount LED Ring Light is a high-output LED light in an aluminum housing. Housing uses industry-standard T-slots for ease of mounting. Ring lights are available in light outputs of white, red, amber, blue, green, cyan, IR, and UV. Ring lights include an integrated constant current driver with a built-in strobe input with the option for PNP or NPN trigger control. No need for an external driver to control the light. The integrated driver also includes variable light intensity control. Light can be controlled by a manual potentiometer or a 0-10 V DC analog signal.

## RD130 EZ Mount Ring Light

### EZ Mount Diffuse Ring Light

The RD130 optimal working distance is between 150 mm and 450 mm.

### RD130 EZ Mount Ring Light Features

- Similar form and features as R130

**PRODUCT FAMILY:**

Ring Light  
RD130

**COLOR:**

470, 505, 530, 625, 850,  
940 & WHI (White)

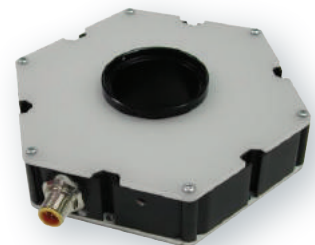

**AVERAGE INTENSITY RATING**

36,000 lux\*

\*Lux measurement taken at surface of RD130



## ODRD130 EZ Mount Ring Light with OverDrive™ Features



- Similar form and features as RD130
- Strobe-only OverDrive™ operation
- OverDrive™ units are 5x brighter than standard high-current LED lights

**PRODUCT FAMILY:**

Ring Light  
ODRD130

**COLOR:**

470, 505, 530, 625, 850,  
940 & WHI (White)

# XR256 High-Speed Strobe Light

## High-Speed/Extreme-Output Light

Capable of emitting up to 5000 strobes per second, the XR256 is pulse-initiated or pulse-following for strobe. The XR256 light has 256 mm<sup>2</sup> (256 of 1 x 1 high-power die) of LED die running at up to 2000 W. For comparison, a standard LED light for machine vision has on average 6–12 mm<sup>2</sup> of LED die running at 6–12 watts. The XR Series lights have an LED die temperature monitor that will shut down the light if the LEDs exceed the maximum duty cycle.

## XR256 High-Speed Strobe Light Features

- Capable of up to 5000 strobes per second
- Uses stored electrical energy to pulse LEDs
- Pulsed LED energy of 2000 W when LEDs are active
- Pulsed LED die current of 180 A
- Available in blue, green, red, white, and IR

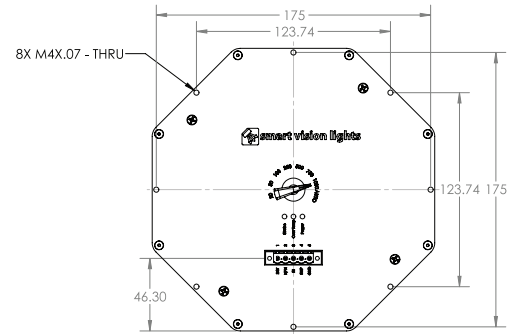
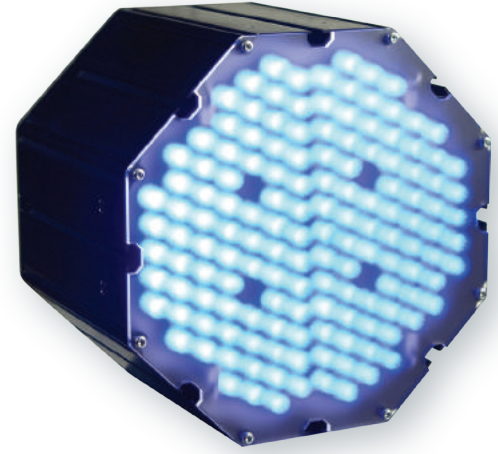
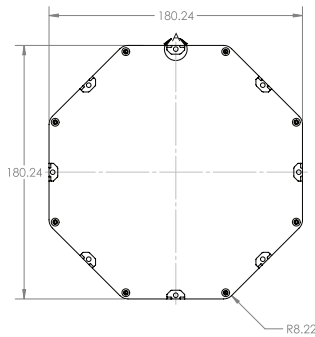
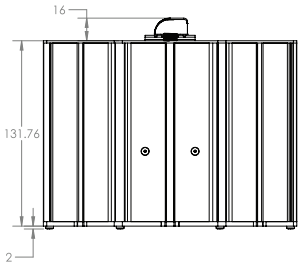

## Light Distribution Data

XR256-WHI

WORKING DISTANCE meter (inches)	PATTERN (80%–100% measured intensity) millimeter (inches)
1 m (39.4")	360 mm (~14") H x 360 mm (~14") V
2 m (78.8")	720 mm (~28") H x 760 mm (30") V

**PRODUCT FAMILY:**

Strobe Light  
XR256

**COLOR:**

470, 530, 625, 850  
& WHI (White)

**LENSES:**

14 = 14 degree  
20 = 20 degree  
30 = 30 degree  
50 = 50 degree  
80 = 80 degree



## XR256 HIGH INTENSITY STROBE LIGHT Application



### OUTDOOR LOG INSPECTION

**CLIENT REQUEST:** A logging operation needed an automated method of determining the outer diameter of de-barked logs to optimize the amount of lumber that could be cut from each log in an outdoor, uncontrolled environment.

**ISSUES:** Developing outdoor machine vision solutions is extremely difficult due to changing ambient light conditions. The illumination system for the final solution would need to provide clear, stable levels of illumination, even in poor weather conditions.

**Vision system:** Microscan 5 MP GigE camera  
**Illumination:** XR256-IR  
**Filter:** IR bandpass filter



**SOLUTION:** An engineering feasibility study determined that the final system would need a very intense, and therefore nonvisible, light to illuminate the log without blinding nearby workers. Our engineers chose an infrared wavelength to protect nearby workers because enclosing the vision system was not an option.

# RL200 Large Ring Light

## Large Ring Light

Large Ring Lights include an integrated constant current driver with a built-in strobe input with option for PNP or NPN trigger control. No need for an external driver to control the light. Intensity of the light can be controlled via 0-10 V remote analog signal or integrated manual potentiometer.

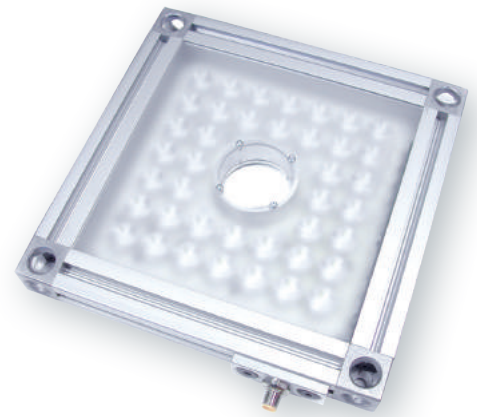

## RL200 Large Ring Light Features

- Different lenses available
- Built-in SMART driver – no external driver needed
- Continuous operation or strobe mode
- Analog intensity via 0-10 V DC signal
- PNP and NPN strobe input

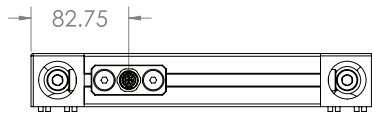

**PRODUCT FAMILY:**

Ring Light  
RL200

**COLOR:**

470, 505, 530, 625, 850  
& WHI (White)

**LENSES:\***

N = Narrow  
L = Line

*\*Wide lens is standard*



## Light Distribution Data

RL200-XXX-W

WORKING DISTANCE meter (inches)	PATTERN (80%–100% measured intensity) cm (inches)
.5 m (20")	21 cm (8") D
1 m (40")	35 cm (14") D
Typical output performance	
Distance = .5 m	20,000
	OverDrive™ 100,000
<i>Illumination measurement taken on White Lights – 6500 K</i>	

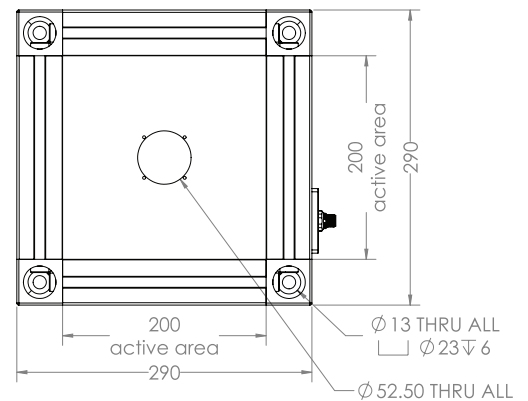

## ODRL200 Large Ring Light with OverDrive™ Features

- Similar form and features as RL200
- 45 mm industrial frame with T-slot
- Strobe-only OverDrive™ operation
- OverDrive™ units are 5x brighter than standard high-current LED lights

**PRODUCT FAMILY:**

Ring Light  
ODRL200

**COLOR:**

470, 505, 530, 625, 850,  
940 & WHI (White)

**LENSES:\***

N = Narrow

*\*Wide lens is standard*

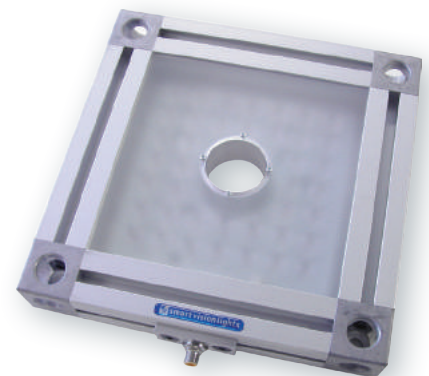

# RL300 Large Ring Light

## Large Ring Light

### RL300 Large Ring Light Features

- Similar form and features as RL200

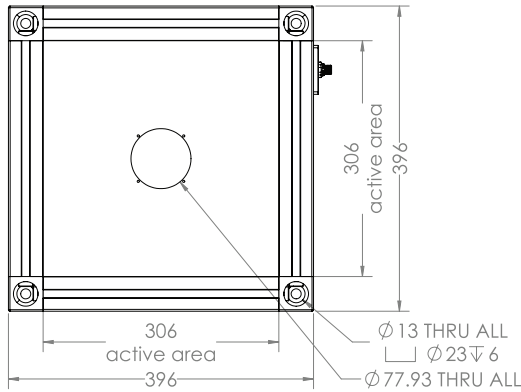
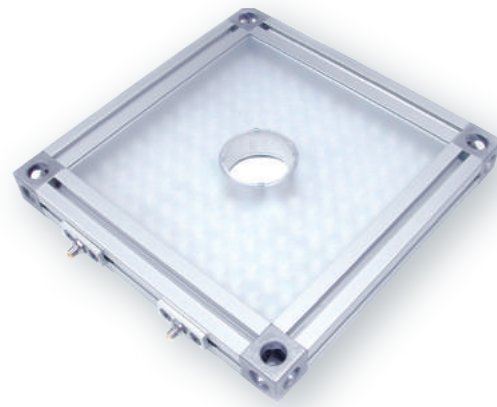

## Light Distribution Data

RL300-XXX

WORKING DISTANCE meter (inches)	PATTERN (80%–100% measured intensity) cm (inches)
.5 m (20")	23 cm (9") D
1 m (40")	37 cm (14.5") D
Typical output performance	
Distance = .5 m	25,000
	OverDrive™ 125,000
Illumination measurement taken on White Lights – 6500 K	

#### PRODUCT FAMILY:

Ring Light  
RL300

#### COLOR:

470, 505, 530, 625, 850  
& WHI (White)

#### LENSES:\*

N = Narrow

\*Wide lens is standard

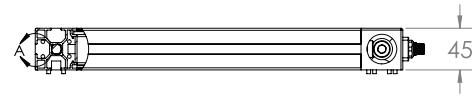
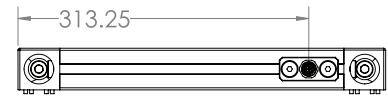

## ODRL300 Large Ring Light with OverDrive™ Features

- Similar form and features as RL300
- 45 mm industrial frame with T-slot
- Strobe-only OverDrive™ operation
- OverDrive™ units are 5x brighter than standard high-current LED lights

#### PRODUCT FAMILY:

Ring Light  
ODRL300

#### COLOR:

470, 505, 530, 625, 850,  
940 & WHI (White)

#### LENSES:\*

N = Narrow

\*Wide lens is standard

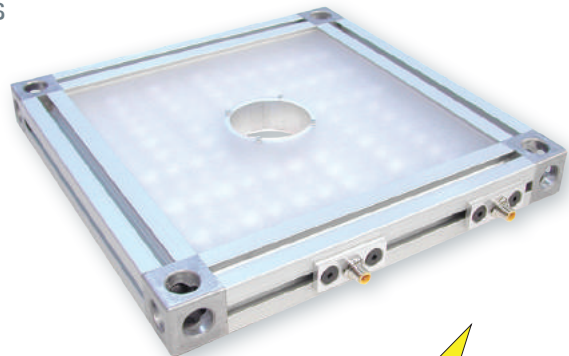

# SXP30 Projector Light

## Structured Light Projectors

The SXP30 Series Projector Light offers the most intense projected pattern offered from an LED. The 9 mm<sup>2</sup> die size emits 9x the intensity as a standard high-output LED. The housing is constructed of finned 6061-T6 aluminum and designed to dissipate as much heat as possible, therefore allowing the LED to be run at a much higher current than the standard 1 mm<sup>2</sup> die LEDs. Multiple interchangeable pattern styles are available along with optional custom patterns. The SXP30 Series is able to project a thinner and more defined pattern of light compared to laser projectors, making the SXP30 a more accurate light.



## SXP30 Projector Light Features

- 5-pin M12 quick disconnect
- Multiple interchangeable patterns
- Built-in SMART driver - no external driver needed
- PNP and NPN strobe input
- Continuous operation or strobe mode
- Analog intensity 0-10 V DC signal

**PRODUCT FAMILY:**

Projector Light  
SXP30

**COLOR:**

470, 530, 625, 850  
& WHI (White)

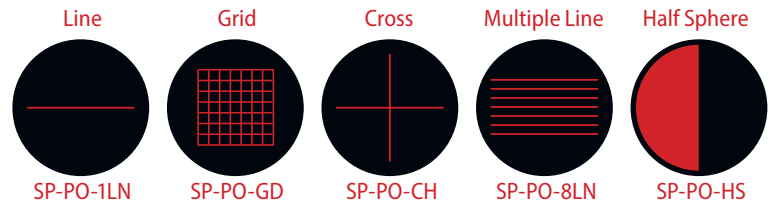
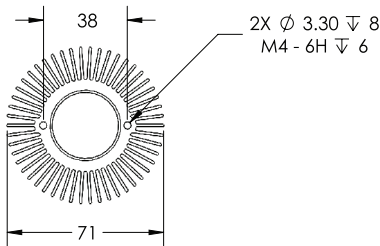

## Projector pattern options

Standard patterns are available and custom patterns can be etched. Patterns can be changed.

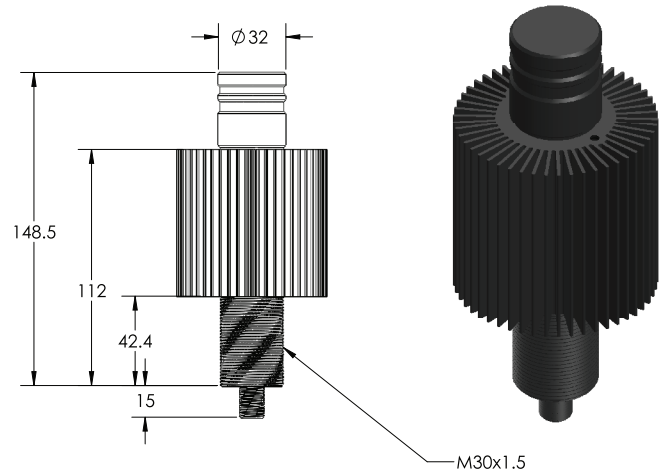

## ODSXP30 Projector Light with OverDrive™ Features

- Similar form and features as SXP30
- Multiple interchangeable patterns
- 15 A pulsed through LED
- Up to 2000 strobes per second
- Maximum strobe time 50 ms

**PRODUCT FAMILY:**

Projector Light  
ODSXP30

**COLOR:**

470, 530, 625, 850  
& WHI (White)





# Pattern Projector Light Application and Options

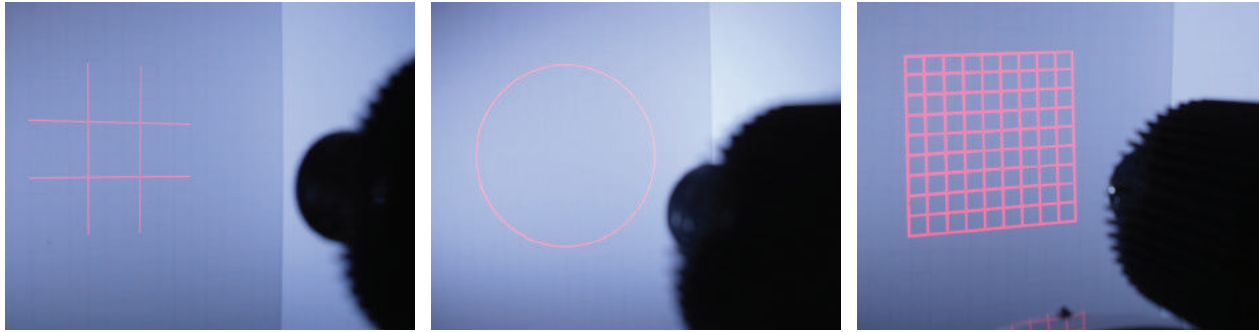

Images above show custom patterns.

## Configurable to Any Working Distance

Pattern projectors must utilize a standard C-mount lens for pattern focus. **Smart Vision Lights** recommends  $\frac{2}{3}$  inch or larger format lenses. Telecentric lenses also can be used for telecentric pattern projection. Standard format lenses with pattern area sizes and working distances are listed in the chart below. Chart sizes are approximations due to differences in lens manufacturers. For more information, contact **Smart Vision Lights**.

### Projector Distance Chart

		W = Working Distance										
		100 mm	150 mm	200 mm	300 mm	400 mm	500 mm	600 mm	750 mm	1000 mm	1500 mm	2000 mm
A = Diameter of Area	60 mm			25			50					
	100 mm	8	12	16	25	35	35	50	50			
	150 mm	6	8	12	16	25	25	35	35	50	75	
	200 mm		6	8	12	16	16	25	25	35	50	100
	300 mm			6	8	12	12	16	16	25	35	50
	400 mm				6	8	8	12	12	16	25	35
500 mm					6			8	12	16	25	25

Number in box represents the focal length of lens. (Example: 6 is a 6 mm focal length lens.)

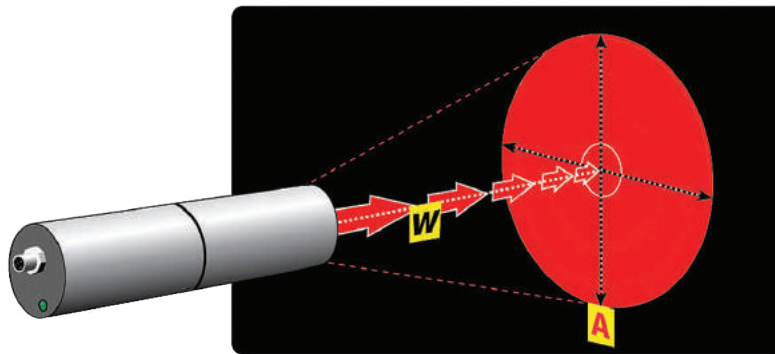

## SP-PO-xxx

- Standard Pattern Etching – single-line standard (1LN), single-line thin (1LN-05), 8 line (8LN), half sphere (HS), full sphere (FS), 8 x 8 grid (8 X 8GRID), cross hair (CH), right angle line (RA), 50 x 50 pixel chess board (CB50), 100 x 100 pixel chess board (CB100)

## SP-CSM-EPN

- Custom pattern etching only

## SP-PATTN-KIT

- Standard Pattern Kit – single line (standard), 8 line, half sphere, full sphere, 8x8 grid, cross hair

## LM Series & FL Series

- $\frac{2}{3}$ " format, manual iris C-mount lenses from Kowa and Ricoh



# Line High-Power (LHP) Light

## Line High-Power LED Line Scan

The Line High-Power (LHP) Series uses cutting-edge silicone optics and is ideal for applications using line-scan cameras that require high-intensity illumination, such as web and print applications, packaging, electronics, and flat-panel display inspection. This light also includes internal adjustable focus and 700 W of thermal energy for each foot of light. The LHP is the world's brightest industrial line-scan light at greater than 5 million lux (400,000 lux in low-power mode) and the only scan light on the market to offer polarization (patent pending).

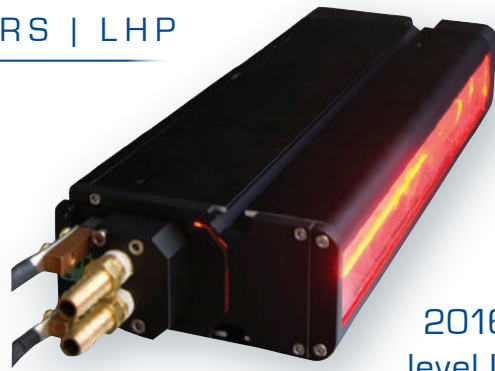

2016 Platinum-level Innovators Awards winner from Vision Systems Design magazine

## LHP Series Light Features

- Built-in driver – no external wiring to a driver
- High- and low-intensity selector
- Interlock system for user protection
- 24 V DC 40 A power supply included
- Available in 365 nm–940 nm and white light
- Optional wire-grid polarizer available
- Available in 300 mm increments up to 3 m

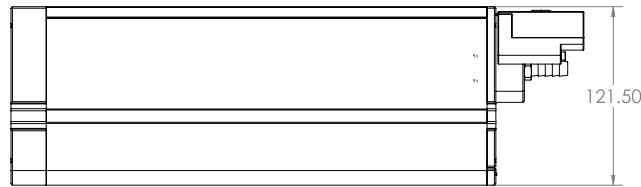

**PRODUCT FAMILY:**  
Line Scan Light  
LHP Series

**LENGTH:**  
300 mm increments  
up to 3 meters

**COLOR:**  
365, 395, 470, 505, 530,  
625, 850, 940 & WHI (White)

**POLARIZER:**  
Optional

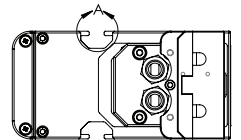

## External Chillers

External cooling allows LHP lights to achieve unparalleled output of up to 5 million lux.

European versions available.



### LHP-CHL-005

- 50 W, 110 V External Chiller for LHP Line Scan Light – CW3000-DG, 110 V AC

### LHP-CHL-02

- 1500 W, 110 V External Chiller for LHP Line Scan Light – CW5200, 110 V AC

### LHP-CHL-03

- 3100 W, 110 V External Chiller for LHP Line Scan Light – CW6000DN, 110 V AC

### LHP-CHL-04

- 4240 W, 230 V External Chiller for LHP Line Scan Light – CW6000DN, 110 V AC

# Line High-Power (LCHP) Light

## Line High-Power LED Line Scan

The Line High-Power (LHCP) Series works in lower-power applications and projects a fixed-focus line with clearly defined edges. The LCHP is a lower-cost alternative to Smart Vision Lights' High-Power Line Scan (LHP Series) light. The LCHP puts out 250,000 lux, compared to 5 million lux for the LHP in water-cooled high-power mode and 400,000 lux for the LHP in uncooled, low-power mode.

### LHCP Series Light Features

- Similar form and features as LHP
- 5-pin M12 connectivity
- External chilling system unnecessary
- Backlight lensing available
- Three wavelength options
- Optional linear polarizer

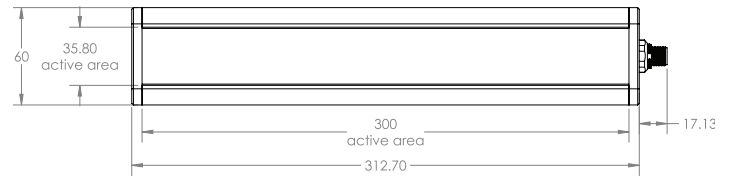
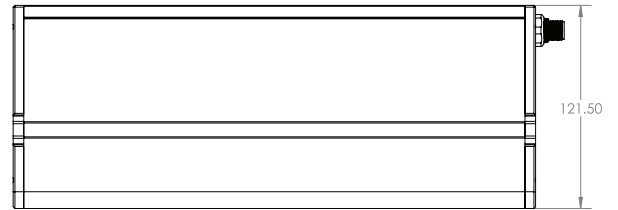
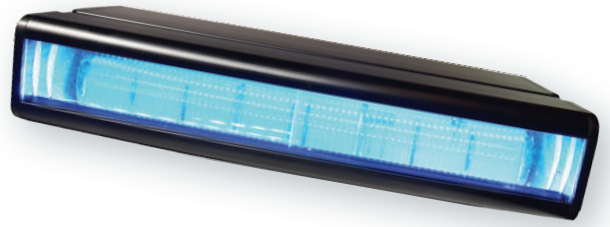
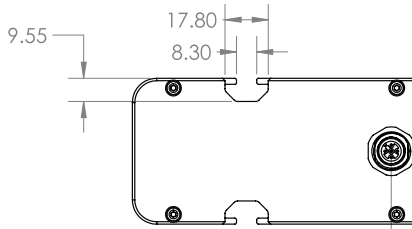

**PRODUCT FAMILY:**  
Line Scan Light  
LCHP Series

**LENGTH:**  
300 mm  
600 mm

**COLOR:**  
470, 625 &  
WHI (White)



## Silicone Optics: Precision Design at Low Cost

Smart Vision Lights' LHP is the first commercial machine vision LED light to use silicone optics. Combining the best properties of glass and plastic, optical-grade silicone enables injection molding of complex optical designs at a low cost. The material offers 95 percent or better light transmission from 365 nm (UV) to 2000 nm (IR). Only silicone optics can handle the LHP's 5 million lux and associated heat without significant degradation over time.

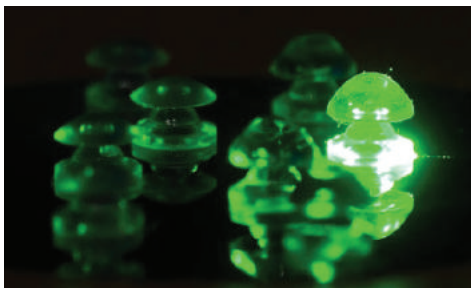

# L300 Linear Light



## Connect a Light

The Connect a Light series of lights simplifies connecting multiple light segments together to create longer, larger illumination fields without the expense of large lights. The L300 linear light array in the Connect a Light Series features an integrated Multi-Drive™ constant current driver that operates continuously or in OverDrive™ strobe mode, runs on 24 V DC, and offers PNP/NPN strobe controls and analog potentiometer pulse duration controls. Available in standard narrow, wide, and line optics with options for all standard and some custom wavelengths.

## L300 Linear Light Features

- Built-in SMART driver – no external driver needed
- PNP and NPN strobe
- Constant or strobed operation
- Dimmable via built-in potentiometer
- Remote intensity control — analog 0–10 V DC
- Easily connects together via cable
- Mounts on aluminum extrusion

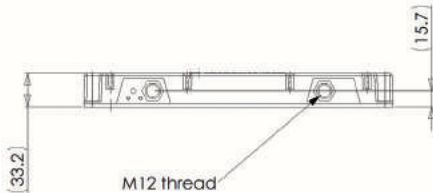
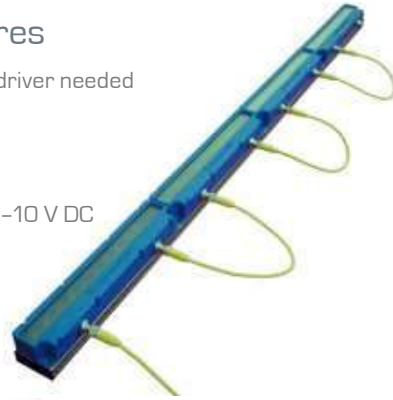

**PRODUCT FAMILY:**  
Linear Light  
L300 Series

**COLOR:**  
365, 395, 470, 505, 530,  
625, 850, 940 & WHI (White)

**LENSES:\***  
W = Wide  
L = Line

*Line optics not available in UV wavelengths  
\*Narrow lens is standard*



## Light Distribution Data

### L300-XXX

WORKING DISTANCE meter (inches)	PATTERN (80%–100% measured intensity) millimeter (inches)
.5 m (19.7")	210 mm (~8") H x 100 mm (~4") V
1 m (39.4")	250 mm (~10") H x 200 mm (~8") V
1.5 m (59")	310 mm (~12") H x 300 mm (~12") V
Typical output performance	
Distance = .5 m	14,000 OverDrive™ 70,000
<i>Illumination measurement taken on White Lights – 6500 K</i>	

### L300-XXX-W

WORKING DISTANCE meter (inches)	PATTERN (80%–100% measured intensity) millimeter (inches)
.5 m (19.7")	220 mm (~9") H x 160 mm (~6") V
1 m (39.4")	460 mm (~18") H x 420 mm (~16.5") V
1.5 m (59")	570 mm (~22") H x 550 mm (~22") V
Typical output performance	
Distance = .5 m	6300 OverDrive™ 31,500
<i>Illumination measurement taken on White Lights – 6500 K</i>	

### L300-XXX-L

WORKING DISTANCE meter (inches)	PATTERN (80%–100% measured intensity) millimeter (inches)
.5 m (19.7")	330 mm (~13") H x 50 mm (~2") V
1 m (39.4")	660 mm (~26") H x 100 mm (~4") V
1.5 m (59")	990 mm (~39") H x 150 mm (~6") V
Typical output performance	
Distance = .5 m	10,000 OverDrive™ 50,000
<i>Illumination measurement taken on White Lights – 6500 K</i>	

## Connector

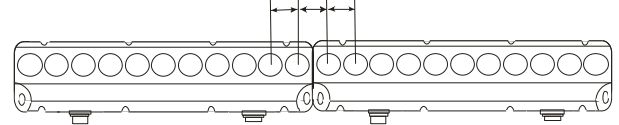

## ODL300 OverDrive™ Linear Light Features

- Similar form and features as L300
- Strobe-only OverDrive™ operation
- OverDrive™ units are 5x brighter than standard high-current LED lights
- Precise current provides stable light intensity
- High-speed, fast response
- Available in 150 mm and 300 mm lengths; call for custom sizes



**PRODUCT FAMILY:**  
Linear Light  
ODL300 Series

**COLOR:**  
365, 395, 470, 505, 530,  
625, 850, 940 & WHI (White)

**LENSES:\***  
W = Wide  
L = Line

*\*Narrow lens is standard*

# LB300 Linear Light

## Connect a Light | Backlight

The LB300 is the backlight version of the L300. It features a backlight lens and is a viable option for silhouetting objects.

### LB300 Linear Light Features

- Similar form and features as L300
- 5-pin M12 quick disconnect
- Option of connecting lights together

**PRODUCT FAMILY:**

Linear Light  
LB300 Series

**COLOR:**

470, 505, 530, 625, 850,  
940 & WHI (White)



**AVERAGE INTENSITY RATING**

36,000 lux\*

\*Lux measurement taken at surface of LB300



## ODLB300 OverDrive™ Linear Light Features

- Similar form and features as LB300
- Strobe-only OverDrive™ operation
- OverDrive™ units are 5x brighter than standard high-current LED lights

**PRODUCT FAMILY:**

Linear Light  
ODLB300 Series

**COLOR:**

470, 505, 530, 625, 850,  
940 & WHI (White)



## LINEAR LIGHT Application

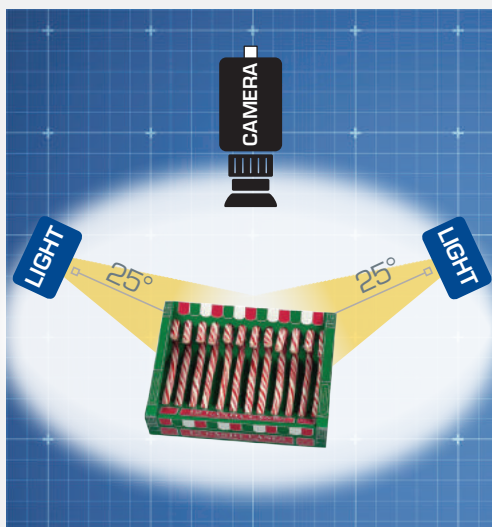

### PRESENCE/ABSENCE Candy Cane Inspection

**CLIENT REQUEST:** Inspection of completed candy cane boxes to ensure box is full and proper sticker/label is on front.

**ISSUES:** Boxes and canes may be any color or combination of colors.

**Illumination:** (2) L300-850 [300 mm Linear Light 850 nm IR "Connect a Light"]

**Light angle:** 25° across case, 300 mm from edges, and 200 mm above platform the case rests on

**Filter:** BP850



**SOLUTION:** To combat this variation, Smart Vision Lights recommended **infrared (IR) illumination**, which is invisible to humans and also eliminates various colors of objects, providing a grayscale image result. IR light is also used to see through packaging to inspect goods since it penetrates plastic wrappings, eliminating any potential for glare or reflection. With the IR light, all the canes appear very bright white. If a cane is missing, the location where it should be **appears dark**.

## LW300 Linear Light

### Connect a Light | Washdown

The LW300 series features a 100 percent waterproof stainless-steel enclosure specially designed for food industry and washdown environments where water and corrosive materials are present. All circuitry is enclosed in an epoxy potting compound, further protecting the light from dust, debris, and all other contaminants. The LW300 is part of the Connect a Light Series of lights that simplify connecting multiple light segments together to create longer, larger illumination fields without the expense of large lights.

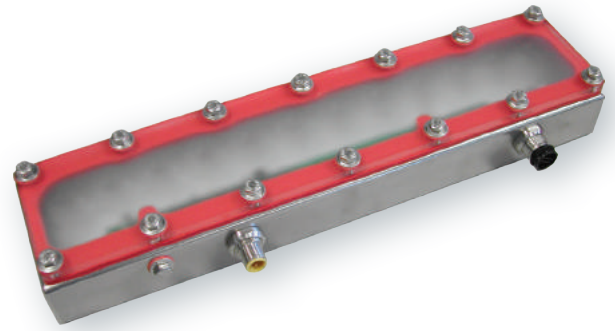

See Washdown Lights section starting on page 51 for more information.

### ODLW300 OverDrive™ Linear Light Features

- Similar form and features as LW300
- Strobe-only OverDrive™ operation
- OverDrive™ units are 5x brighter than standard high-current LED lights
- Maximum strobe time 125 ms
- Up to 5000 strobes per second

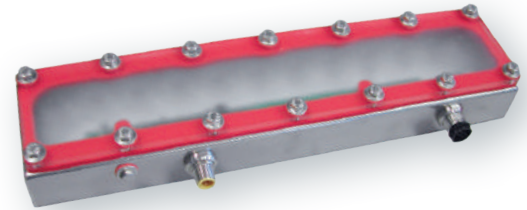

See Washdown Lights section starting on page 51 for more information.

### LINEAR LIGHT Application



#### REFLECTIVE PART INSPECTION

**CLIENT REQUEST:** Inspect reflective metal assembly made of multiple components. Verify presence of components and diameter and location of bolt holes, among other features.

**ISSUES:** Finding the right illumination system for spatial measurements of metal parts is a challenge due the possibility of hot spots and shadows creating artifacts that confuse image processing algorithms.

**Vision system:** 2 Cognex Insight 7010 cameras

**Illumination:** 2 LC300-505 linear lights

**Lens:** 2 Moritex MLM1214MP

**Filter:** 2 Blue Light Bandpass Filters

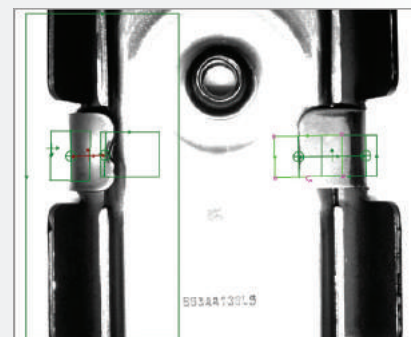

**SOLUTION:** An engineering feasibility study determined that by identifying metal tabs and measuring the tabs' spatial properties, the customer could automate an assembled part inspection task and reduce rework of downstream production. By using two cameras — each with its own blue LC300-505 linear light source and complementary blue light bandpass filter mounted to the camera so that only the LC300 light is seen by the camera — the designer increased the reliability of the metallic tab inspection process while boosting throughput at the inspection station.

# LC300 Linear Light

## Grey Series

Part of SVL's cost-effective Grey Series Lighting, the LC300 offers an integrated constant current driver built into the light, eliminating the need for any external components in the lighting system. Does not include light intensity adjustment or daisy-chain capabilities.

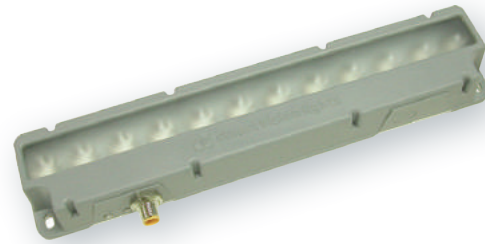

## LC300 Linear Light Features

- 12 high-current LEDs
- M12 quick disconnect
- Built-in driver – no external wiring to a driver
- PNP and NPN strobe input
- Continuous operation or strobe
- Illumination patterns available in standard tight, wide expanded, and line

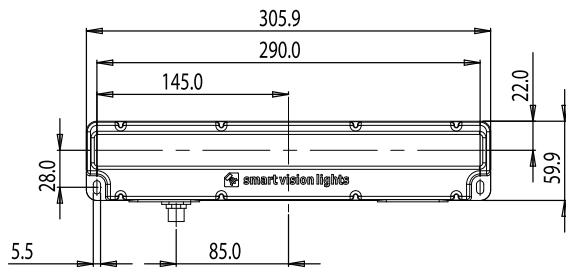

**PRODUCT FAMILY:**  
Linear Light  
LC300

**COLOR:**  
470, 530, 625, 850  
& WHI [White]

**LENSES:\***  
W = Wide  
L = Line

\*Narrow lens is standard

## Light Distribution Data

### LC300-XXX

WORKING DISTANCE meter (inches)	PATTERN (80%–100% measured intensity) millimeter (inches)
.5 m (19.7")	210 mm (~8") H x 100 mm (~4") V
1 m (39.4")	250 mm (~10") H x 200 mm (~8") V
1.5 m (59")	310 mm (~12") H x 300 mm (~12") V
Typical output performance	
Distance = .5 m	Illumination (Lux) 14,000
Illumination measurement taken on White Lights – 6500 K	

### LC300-XXX-W

WORKING DISTANCE meter (inches)	PATTERN (80%–100% measured intensity) millimeter (inches)
.5 m (19.7")	220 mm (~9") H x 160 mm (~6") V
1 m (39.4")	460 mm (~18") H x 420 mm (~16.5") V
1.5 m (59")	570 mm (~22") H x 550 mm (~22") V
Typical output performance	
Distance = .5 m	Illumination (Lux) 6300
Illumination measurement taken on White Lights – 6500 K	

### LC300-XXX-L

WORKING DISTANCE meter (inches)	PATTERN (80%–100% measured intensity) millimeter (inches)
.5 m (19.7")	330 mm (~13") H x 50 mm (~2") V
1 m (39.4")	660 mm (~26") H x 100 mm (~4") V
1.5 m (59")	990 mm (~39") H x 150 mm (~6") V
Typical output performance	
Distance = .5 m	Illumination (Lux) 10,000
Illumination measurement taken on White Lights – 6500 K	

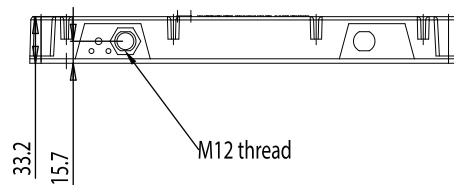

## Linear Light Accessories



### Power Cables

Length	Part #
5 m	5PM12-5
10 m	5PM12-10
15 m	5PM12-15



### Jumper Cables

Length	Part #
300 mm	5PM12-J300
1 m	5PM12-J1000
2 m	5PM12-J2000



### Mount

Description	Part #
3-Axis Pan & Tilt Mount	PB300-M5



### Mounting Rails

Length	Part #
300 mm	LEXT300
600 mm	LEXT600
900 mm	LEXT900
1200 mm	LEXT1200

Custom sizes available



### Diffuser

Description	Part #
Diffuser Kit for L300/ L300/ ODL300	L300-DKIT



### Linear Polarizer

Description	Part #
L300/ L300-LP ODL300	L300/ L300-LP ODL300

# LE Series Linear Light

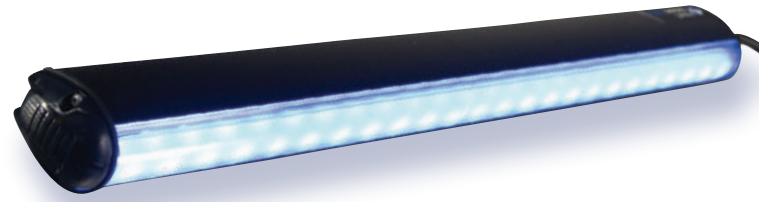

## Everything Light

Inspired by European style, the rugged LE Series offers everything needed in one sleek design with the convenience of T-slot mounting. The Multi-Drive™ driver allows the light to operate in constant output mode or in OverDrive™ strobe operation. The aluminum design provides maximum heat dissipation and ventilation to allow for pressure equalization.

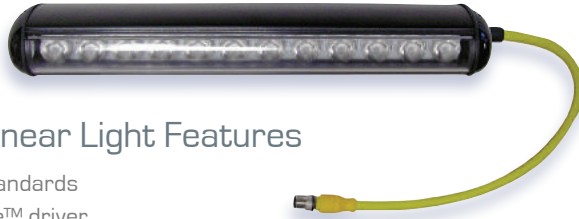

## LE Series Linear Light Features

- Sealed to IP65 standards
- Built-in Multi-Drive™ driver
- 5-pin M12 connector
- PNP and NPN signal options
- Continuous operation or strobe
- Drip-proof/splash-proof
- Available in 300, 600, 900, and 1200 mm lengths; custom sizes available

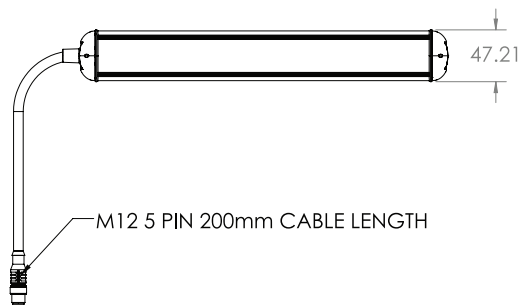
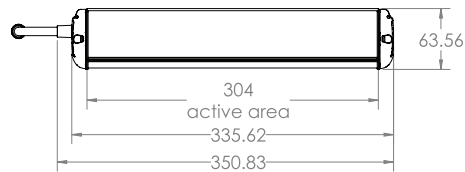

**PRODUCT FAMILY:**  
Linear Light  
LE Series

**LENGTH:**  
300 mm  
600 mm  
900 mm  
1200 mm

**COLOR:**  
470, 505, 530,  
625, 850, 940  
& WHI [White]

**LENSES: \***  
W = Wide  
L = Line

\*Narrow lens is standard

## Light Distribution Data

### LE300-XXX

WORKING DISTANCE meter (inches)	PATTERN (80%–100% measured intensity) millimeter (inches)
.5 m (19.7")	210 mm (~8") H x 100 mm (~4") V
1 m (39.4")	250 mm (~9.8") H x 210 mm (~8.3") V
1.5 m (59")	270 mm (~10.6") H x 255 mm (~10") V
Typical output performance	
Distance = .5 m	8800 OverDrive™ 44,000
Illumination measurement taken on White Lights – 6500 K	

### LE300-XXX-W

WORKING DISTANCE meter (inches)	PATTERN (80%–100% measured intensity) millimeter (inches)
.5 m (19.7")	220 mm (~9") H x 160 mm (~6") V
1 m (39.4")	460 mm (~18") H x 420 mm (~16.5") V
1.5 m (59")	570 mm (~22") H x 550 mm (~22") V
Typical output performance	
Distance = .5 m	5200 OverDrive™ 26,000
Illumination measurement taken on White Lights – 6500 K	

### LE300-XXX-L

WORKING DISTANCE meter (inches)	PATTERN (80%–100% measured intensity) millimeter (inches)
.5 m (19.7")	330 mm (~13") H x 50 mm (~2") V
1 m (39.4")	660 mm (~26") H x 100 mm (~4") V
1.5 m (59")	990 mm (~39") H x 150 mm (~6") V
Typical output performance	
Distance = .5 m	6800 OverDrive™ 34,000
Illumination measurement taken on White Lights – 6500 K	

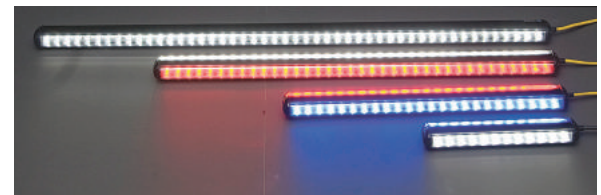



# LHF300 Linear Light

## Fluorescent Replacement

Part of the Direct Connect series linear lights, which offers integrated light-to-light connectors, eliminating the need for cable connectors to string lights together. The LHF300 series was designed as a direct LED replacement for standard fluorescent lighting. The LHF300 array uses 30 high-intensity LEDs and features a diffuse lens cover designed to disperse the light in the same fashion as a fluorescent light of equivalent length. Available in 3 connector options: LHF300-EC: Power Output End Cap; LHF300-E-PKIT: M12 Power Output Connector; LHF300-PKIT: M12 Power Input Connector

## LHF300 Linear Light Features

- Daisy-chain up to 8 units
- Built-in driver - 24 V DC
- T-slot for mounting and connecting together
- NPN strobe input
- Continuous operation or strobe mode
- Homogenous light pattern



## Light Distribution Data

LHF300-XXX

WORKING DISTANCE meter (inches)	PATTERN (80%–100% measured intensity) millimeter (inches)
.5 m (~19.7")	570 mm (~22.4") H x 580 mm (~22.8") W
1 m (~39.4")	800 mm (~31.5") H x 800 mm (~31.5") W
Typical output performance	Illumination (Lux)
Distance = .5 m	1700
Distance = 1 m	520
<i>Illumination measurement taken on White Lights – 5000 K</i>	



LHF300-M12 & ODLHF300-M12 option pictured at left comes with M12 pre-assembled.

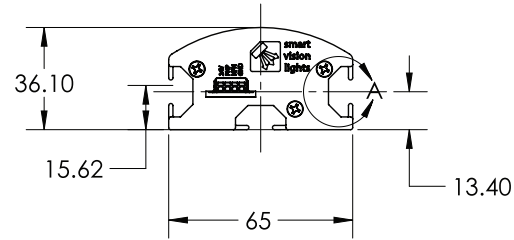
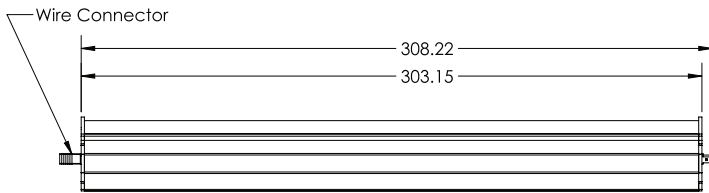

Pictured with LHF300-BKT.

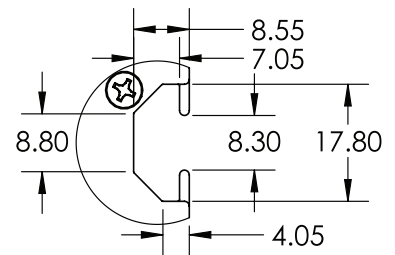

**PRODUCT FAMILY:**  
Fluorescent Replacement  
LHF300

**COLOR:**  
470, 625, 850 &  
WHI (White)



## ODLHF300 OverDrive™ Linear Light Features

- Similar form and features as LHF300
- Strobe-only OverDrive™ operation
- OverDrive™ units are 5x brighter than standard high-current LED lights

**PRODUCT FAMILY:**  
Fluorescent Replacement  
ODLHF300

**COLOR:**  
470, 625, 850 &  
WHI (White)



# LX150 Linear Light

## Direct Connect Series

The modular design of the LX150 linear light, part of the Direct Connect Linear Light Series, offers integrated light-to-light connectors, eliminating the need for cable connectors to string lights together. This innovative design requires power connection to the first light but eliminates the need for jumper cables to pass power through to the next, enabling tailored-length solutions in increments of 150 mm.

## LX150 Linear Light Features

- Built-in driver – no external wiring to a driver
- PNP and NPN strobe input
- Continuous operation or strobe mode
- Dimmable via built-in potentiometer
- Analog intensity 0–10 V DC signal
- T-slot for mounting and connecting lights together

**PRODUCT FAMILY:**

Linear Light  
LX150

**COLOR:**

365, 395, 470, 505, 530,  
625, 850, 940 & WHI (White)

**LENSES:\***

W = Wide  
L = Line

\*Narrow lens is standard

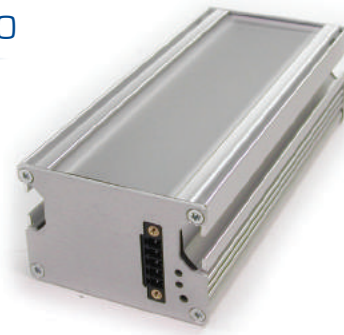

## Light Distribution Data

### LX150-XXX

WORKING DISTANCE meter (inches)	PATTERN (80%–100% measured intensity) millimeter (inches)
.5 m (19.7")	130 mm (~5") H x 100 mm (~4") V
1 m (39.4")	210 mm (~8") H x 200 mm (~8") V
1.5 m (59")	280 mm (~11") H x 280 mm (~11") V
Typical output performance	
Distance = .5 m	12,000
<i>Illumination measurement taken on White Lights – 6500 K</i>	

### LX150-XXX-W

WORKING DISTANCE meter (inches)	PATTERN (80%–100% measured intensity) millimeter (inches)
.5 m (19.7")	180 mm (~7") H x 180 mm (~7") V
1 m (39.4")	350 mm (~14") H x 300 mm (~12") V
1.5 m (59")	650 mm (~26") H x 650 mm (~26") V
Typical output performance	
Distance = .5 m	4200
<i>Illumination measurement taken on White Lights – 6500 K</i>	

### LX150-XXX-L

WORKING DISTANCE meter (inches)	PATTERN (80%–100% measured intensity) millimeter (inches)
.5 m (19.7")	200 mm (~8") H x 100 mm (~4") V
1 m (39.4")	520 mm (~20") H x 200 mm (~8") V
1.5 m (59")	710 mm (~28") H x 280 mm (~11") V
Typical output performance	
Distance = .5 m	10,000
<i>Illumination measurement taken on White Lights – 6500 K</i>	

# LXB150 Backlight

## Direct Connect Backlight

## LXB150 Backlight Features

- Can be used as a backlight or diffuse front light

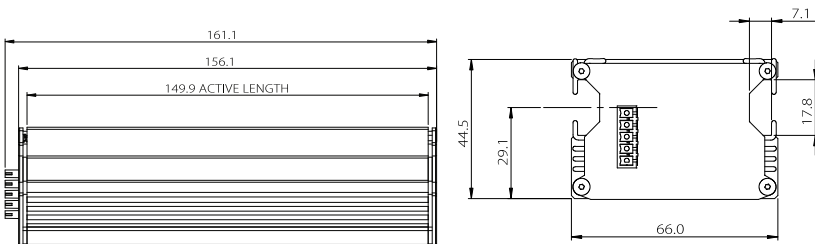

**PRODUCT FAMILY:**

Linear Light  
LXB150

**COLOR:**

470, 505, 530, 625, 850,  
940 & WHI (White)

# LX300 Linear Light

## Direct Connect Series

Featuring the same plug-and-play design as the LX150, the LX300 linear light is available in 300 mm increments.

## LX300 Linear Light Features

- Similar form and features as L300
- Integrated T-slot for mounting and connecting lights together



## Light Distribution Data

### LX300-XXX

WORKING DISTANCE meter (inches)	PATTERN (80%–100% measured intensity) millimeter (inches)
.5 m (19.7")	240 mm (~9") H x 100 mm (~4") V
1 m (39.4")	250 mm (~10") H x 220 mm (~9") V
1.5 m (59")	360 mm (~14") H x 360 mm (~14") V
Typical output performance	
Distance = .5 m	18,000
<i>Illumination measurement taken on White Lights – 6500 K</i>	

### LX300-XXX-W

WORKING DISTANCE meter (inches)	PATTERN (80%–100% measured intensity) millimeter (inches)
.5 m (19.7")	240 mm (~9") H x 180 mm (~7") W
1 m (39.4")	400 mm (~16") H x 350 mm (~14") W
1.5 m (59")	530 mm (~21") H x 540 mm (~21") W
Typical output performance	
Distance = .5 m	8300
<i>Illumination measurement taken on White Lights – 6500 K</i>	

### LX300-XXX-L

WORKING DISTANCE meter (inches)	PATTERN (80%–100% measured intensity) millimeter (inches)
.5 m (19.7")	240 mm (~9") H x 100 mm (~4") V
1 m (39.4")	510 mm (~20") H x 190 mm (~8") V
1.5 m (59")	830 mm (~33") H x 330 mm (~13") V
Typical output performance	
Distance = .5 m	14,000
<i>Illumination measurement taken on White Lights – 6500 K</i>	

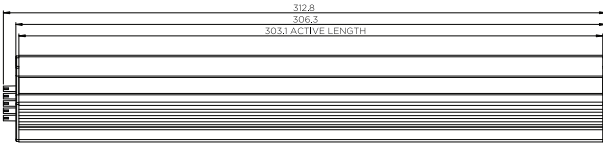

### PRODUCT FAMILY:

Linear Light  
LX300

### COLOR:

365, 395, 470, 505, 530,  
625, 850, 940 & WHI (White)

### LENSES:\*

W = Wide  
L = Line

\*Narrow lens is standard



# LXB300 Backlight

## Direct Connect Backlight

## LXB300 Linear Light Features

- Can be used as backlight or diffuse front light

### PRODUCT FAMILY:

Linear Light  
LXB300

### COLOR:

470, 505, 530, 625, 850,  
940 & WHI (White)



## ODLX150/ODLX300 Linear Lights with OverDrive™ Features

- Many of the same form and features as LX150 and LX300
- Strobe-only OverDrive™ operation
- OverDrive™ units are 5x brighter than standard high-current LED lights



# COME SEE WHY OUR MINI-LINIs ARE THE CLEAR CHOICE



VisionSystems DESIGN  
**2017 Innovators Awards**  
**GOLD**

THEM US

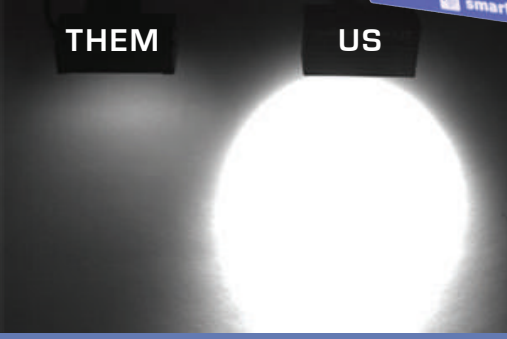

## MINI LIGHTS | LM45

### LM45 Mini Linear Light



#### Mini Linear Light (Mini Lini)

The LM45 Series of compact linear lights features an integrated Multi-Drive™ constant current driver that operates continuously or in OverDrive™ strobe mode depending on wiring method. The light can be mounted via a rear T-slot channel, also offers overcurrent protection and PNP and NPN strobe input. The Mini Lini comes standard with a narrow lens, although wide and line lenses are available. With housing just 51 mm long, the LM45 puts out unprecedented levels of light in one of the industry's smallest footprints.

#### LM45 Mini Linear Light Features

- 5-pin M12 quick disconnect
- Built-in SMART driver - no external driver needed
- PNP and NPN strobe
- Constant or strobed operation
- Remote intensity control — analog 0–10 V DC
- Available in white, blue, green, red, and IR



<b>PRODUCT FAMILY:</b> Mini Linear LM45 Series	<b>COLOR:</b> 470, 530, 625, 850 & WHI (White)	<b>LENSES:*</b> W = 80° Wide
--	--	---------------------------------

\*40 degree lens is standard

#### Light Distribution Data

##### LM45-XXX

WORKING DISTANCE meter (inches)	PATTERN (80%–100% measured intensity) millimeter (inches)
.25 m (9.84")	120 mm (~4.7") H x 125 mm (~4.9") V
.5 m (19.7")	260 mm (~10.2") H x 260 mm (~10.2") V
<b>Typical output performance</b>	
Distance = .25 m	3600 OverDrive™ 18,000
Illumination measurement taken on White Lights – 6500 K	

##### LM45-XXX-W (80° lens)

WORKING DISTANCE meter (inches)	PATTERN (80%–100% measured intensity) millimeter (inches)
.25 m (9.84")	240 mm (~9.4") H x 250 mm (~9.8") V
.5 m (19.7")	520 mm (~20.4") H x 520 mm (~20.4") V
<b>Typical output performance</b>	
Distance = .25 m	1200 OverDrive™ 6000
Illumination measurement taken on White Lights – 6500 K	

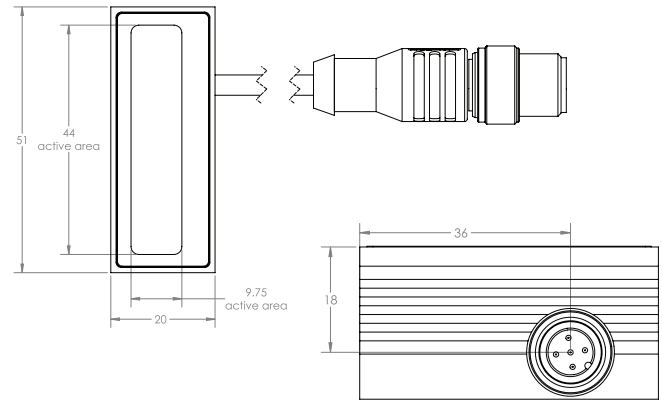

# LM75 Mini Linear Light

## Mini Linear Light

At 80 mm long, the LM75 shares the same form and features as the LM45 but includes 8 high-output LEDs, compared to the LM45's 4 LEDs.

**PRODUCT FAMILY:**

Mini Linear  
LM75 Series

**COLOR:**

470, 530, 625, 850  
& WHI (White)

**LENSES\*:**

W = 80° Wide

\*40 degree lens is standard

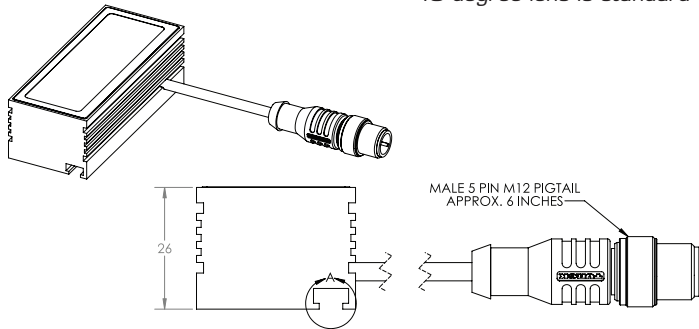

## Light Distribution Data

### LM75-XXX

WORKING DISTANCE meter (inches)	PATTERN (80%–100% measured intensity) millimeter (inches)	
.25 m (9.84")	125 mm (~4.9") H x 125 mm (~4.9") V	
.5 m (19.7")	250 mm (~9.8") H x 255 mm (~10") V	
Typical output performance		illumination (Lux)
Distance = .25 m		8300    OverDrive™ 41,000
illumination measurement taken on White Lights – 6500 K		

### LM75-XXX-W (80° lens)

WORKING DISTANCE meter (inches)	PATTERN (80%–100% measured intensity) millimeter (inches)	
.25 m (9.84")	240 mm (~9.4") H x 250 mm (~9.8") V	
.5 m (19.7")	520 mm (~20.4") H x 520 mm (~20.4") V	
Typical output performance		illumination (Lux)
Distance = .25 m		2700    OverDrive™ 13,600
illumination measurement taken on White Lights – 6500 K		

# RM75 Mini Ring Light

## Mini Ring Light

The RM75 Series of mini ring lights features an integrated Multi-Drive™ constant current driver that operates in continuous or OverDrive™ strobe mode depending on wiring method. The light also offers over-current protection and PNP and NPN strobe input.

## RM75 Mini Ring Light Features

- 5-pin M12 quick-disconnect
- Built-in Multi-Drive™ driver
- PNP and NPN strobe
- Constant or strobed operation
- Remote intensity control — analog 0–10 V DC

**PRODUCT FAMILY:**

Small Ring  
RM75 Series

**COLOR:**

470, 530, 625, 850  
& WHI (White)



WORKING DISTANCE millimeter (meter)	INTENSITY IN LUX	
100 mm (.1 m)	20,000 lux*	OverDrive™ 160,000 lux*

\*Lux measurement taken at surface of RM75

# SX30 Prox Light Series

## 30 mm Barrel Spot Lights

The Prox Light Series of spot lights features single 5 W LEDs in small 30 mm barrel sensor housings. The housings are industry-standard threaded-barrel M30 x 1.5 style used for proximity and photoelectric sensors. The lights are available in white, red, amber, blue, green, cyan, IR, and UV. The Prox Light Series includes an integrated Multi-Drive™ constant current driver that operates continuously or in OverDrive™ strobe mode with PNP/NPN trigger control. Multiple variations of this product are available, including a strobe-only ultra-high intensity OverDrive™ model, remote head unit, fiber optic illuminator, and adjustable spot.

### SX30 Prox Light Features

- M12 quick disconnect
- PNP and NPN strobe input
- Built-in SMART driver - no external driver needed
- Continuous operation or strobe mode
- Analog intensity 0-10 V DC signal
- Available with standard 14 degree, optional 30 degree "wide," and elliptical "line" optics

**PRODUCT FAMILY:**

Prox Light  
SX30

**COLOR:**

365, 395, 470, 505, 530,  
625, 850, 940 & WHI (White)

**LENSES:\***

W = Wide  
L = Line

\*Narrow lens is standard

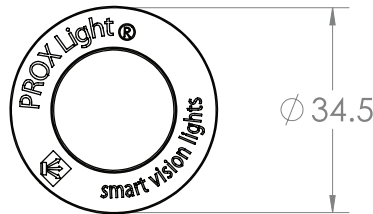
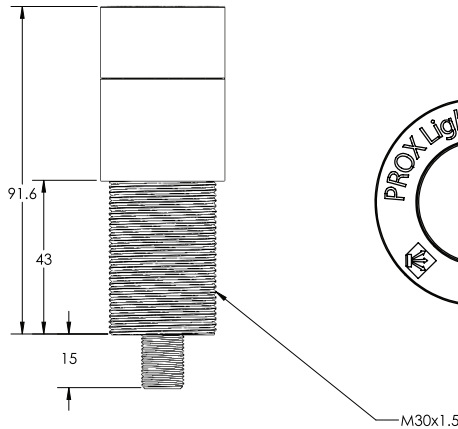

### Light Distribution Data

**SX30-XXX**

WORKING DISTANCE meter (inches)	PATTERN (80%–100% measured intensity) millimeter (inches)
.5 m (19.7")	80 mm (~3") D
1 m (39.4")	185 mm (~7") D
Typical output performance	
Distance = .5 m	4200   OverDrive™ 21,000
<i>Illumination measurement taken on White Lights – 6500 K</i>	

**SX30-XXX-W**

WORKING DISTANCE meter (inches)	PATTERN (80%–100% measured intensity) millimeter (inches)
.5 m (19.7")	205 mm (~8") D
1 m (39.4")	415 mm (~16") D
Typical output performance	
Distance = .5 m	1300   OverDrive™ 6500
<i>Illumination measurement taken on White Lights – 6500 K</i>	

**SX30-XXX-L**

WORKING DISTANCE meter (inches)	PATTERN (80%–100% measured intensity) millimeter (inches)
.5 m (19.7")	255 mm (~10") H x 115 mm (~4.5") V
1 m (39.4")	460 mm (~18") H x 250 mm (~10") V
Typical output performance	
Distance = .5 m	1900   OverDrive™ 9500
<i>Illumination measurement taken on White Lights – 6500 K</i>	

### ODSX30 OverDrive™ Prox Light Features

- Similar form and features as SX30
- Strobe-only OverDrive™ operation
- OverDrive™ units are 5x brighter than standard high-current LED lights
- 125 ms max pulse width
- Required 10% duty cycle for on/off time

**PRODUCT FAMILY:**

Prox Light  
ODSX30

**COLOR:**

365, 395, 470, 505, 530,  
625, 850, 940 & WHI (White)

**LENSES:\***

W = Wide  
L = Line

\*Narrow lens is standard



# SXA30 Adjustable Prox Light Series



## 30 mm Adjustable Barrel Spot Lights

The SXA30 Series is the first series of spot lights featuring an adjustable-length lens, allowing users to select the correct spot size needed for the specific application without having to adjust the position of the whole light. Equipped with convenient mounting options, the SXA30 also offers a completely homogeneous light pattern at any working distance for a defined and even projected spot.

## SXA30 Adjustable Prox Light Features

- Similar form and features as SX30
- Internal optics assist in providing uniform illumination over spot diameter
- Sliding barrel allows user to increase or decrease spot diameter
- Set screw locks in spot size adjustment

**PRODUCT FAMILY:**

Adjustable Spot  
SXA30

**COLOR:**

365, 395, 470, 505, 530,  
625, 850, 940 & WHI (White)

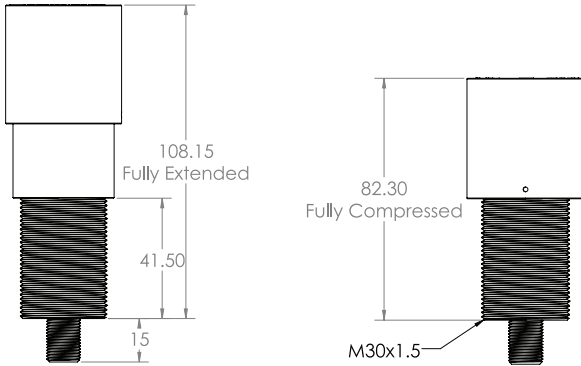

## Light Distribution Data

WORKING DISTANCE meter (inches)	FULLY RETRACTABLE SPOT SIZE DIAMETER mm (inches)	FULLY EXTENDED SPOT SIZE DIAMETER mm (inches)
150 mm (5.9")	210 mm (8")	40 mm (1.5")
300 mm (11.8")	385 mm (15")	60 mm (2.5")
600 mm (23.6")	760 mm (30")	100 mm (4")
1 m (39.4")	1,220 mm (48")	155 mm (6")

AVERAGE INTENSITY RATING	200 mm diameter	2200 lux*
	700 mm diameter	560 lux*



\*Lux measurement taken at .5m distance

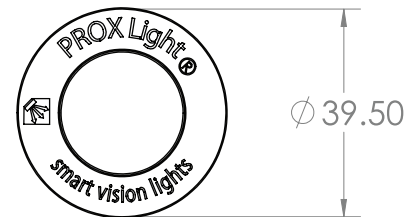

## ODSXA30 OverDrive™ Adjustable Prox Light Features

- Similar form and features as SX30
- Strobe-only OverDrive™ operation
- OverDrive™ units are 5x brighter than standard high-current LED lights
- 125 ms max pulse width
- Required 10% duty cycle for on/off time

**PRODUCT FAMILY:**

Adjustable Spot  
ODSXA30

**COLOR:**

365, 395, 470, 505, 530,  
625, 850, 940 & WHI (White)



AVERAGE INTENSITY RATING	200 mm diameter	5800 lux
	700 mm diameter	1600 lux

\*Lux measurement taken at .5m distance

## SXW30 Prox Light Series

### Washdown 30 mm Barrel Spot Lights

The SXW30 Series features a stainless-steel enclosure for applications in washdown and corrosive environments.



See Washdown Lights section starting on page 51 for more information.

### ODSXW30 OverDrive™ Prox Light Features

- Similar form and features as SXW30
- Strobe-only OverDrive™ operation
- OverDrive™ units are 5x brighter than standard high-current LED lights

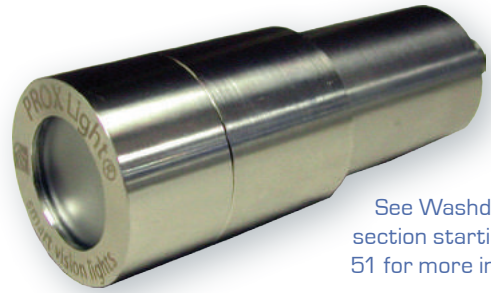

See Washdown Lights section starting on page 51 for more information.

## SXP30 Projector Light

### Structured Light Projectors

The SXP30 Series Projector Light offers the most intense projected pattern offered from an LED. It has similar form and features of the SX30. The ODSXP30 is the strobe-only version with OverDrive™.



See LED Structured Light Pattern Projectors section on page 32 for more information.

## SPOT LIGHT Application

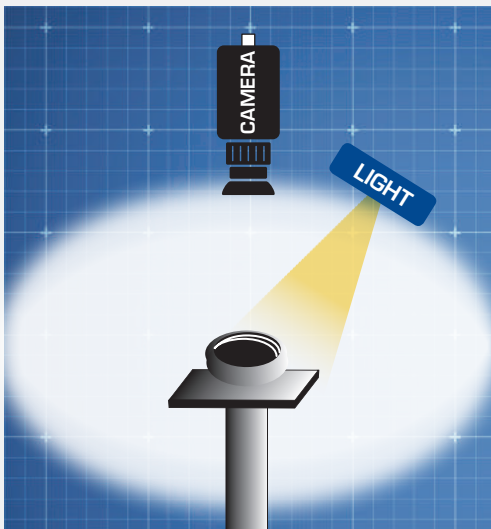

Illumination: SP30 Prox Spot Light

### NARROW LIGHT FOR RECESSED APPLICATIONS

#### Machined Threading Analysis

**CLIENT REQUEST:** Multiple inspection checks for threaded holes in metal parts for thread count and uniformity, chamfer of the machined area for the recessed fastener head.

**ISSUES:** Recessed threading. Possible presence of test fluid in the threaded area.

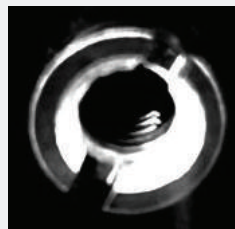

Threaded hole and chamfer area.

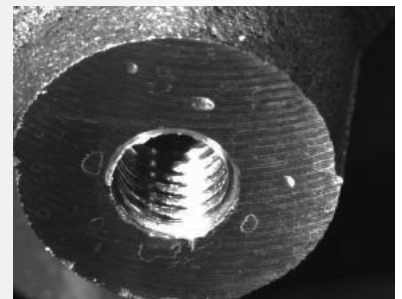

Threaded hole with white test fluid inside, potentially yielding false-negative result.

**SOLUTION:** Application testing in **Smart Vision Lights'** in-house laboratory determined that a spot proximity light provided sufficient collimation of the light to achieve all three goals, including thread analysis deep within the machined hole.



# SX Modified Prox Light Series

## 30 mm Modified Barrel Spot Lights

SXF30 lights were designed with flexibility and focusability in mind. The special fiber adapter allows the projected light to be bent around objects while still containing its intensity and tight focus pattern.

### SXF30 Fiber Bundle Prox Light Features

- 1 m fiber bundle attachment for illuminating tight areas
- Sliding barrel allows user to increase or decrease spot diameter
- Longer fiber lengths available
- True plug-n-play LED fiber light
- Also available in strobe-only ultra-bright OverDrive™ model

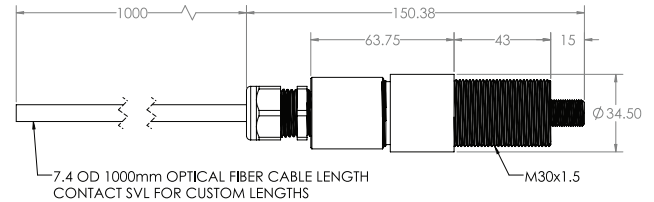

**PRODUCT FAMILY:**

Fiber Bundle  
SXF30

**COLOR:**

470, 505, 530, 625, 850, 940  
& WHI [White]



## ODSXF30 Fiber Bundle OverDrive™ Prox Light Features

- Similar form and features as SXF30
- Strobe-only OverDrive™ operation
- OverDrive™ units are 5x brighter than standard high-current LED lights
- 125 ms max pulse width
- Required 10% duty cycle for on/off time

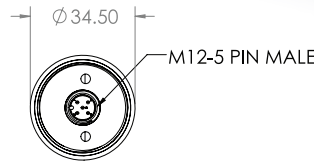

**PRODUCT FAMILY:**

Fiber Bundle  
ODSXF30

**COLOR:**

470, 505, 530, 625, 850, 940  
& WHI [White]

## SX30-RMH Remote Head Prox Light Features

- Similar form and features as SX30
- LED connects to driver housing via 2 m male-to-female jumper cable
- Allows precise placement of LED "head" in small locations not fitting for an entire Prox Light housing
- Longer and shorter jumper cable lengths available
- Also available in strobe-only ultra-bright OverDrive™ model



## Prox Light Accessories



**PB30-M1**  
Swivel Mount



**PB30-M3**  
Slotted Right Angle



**PB30-M6**  
Bolt-On Block Mount



**PSFB-LENS-FC1**  
Focusable Lens  
(SXF30 Only)



**SX30-DKIT-LP**  
Prox Light Diffuser/  
Polarizer Kit

# T-SLOT Light Series

## TSLOT Extrusion LED Light

At twice the performance and half the price, the T-SLOT LED light bar is compatible with most popular brands of .32", 8 mm, and 10 mm aluminum extrusions, including extrusions from 80/20, Bosch, Item, and more.

### TSLOT Extrusion LED Light Features

- LED lighting slides into extrusion T-slot channel; no extra mounting needed
- Homogeneous, uniform LEDs are a cost- and energy-saving replacement for fluorescent lighting
- Modular design allows direct plug-in or daisy-chain of 6 total lights for an 1800 mm length
- Ideal for use in extrusion-built machines, workstations, and robotic cells
- Available in cool white with diffuser cover or warm white clear cover
- M12 power input accessories available
- IP-50 rated

**PRODUCT FAMILY:**

Linear Light  
TSLOT

**SIZE:**

300 mm

**COLOR:**

WHI (White)

**TEMPERATURE:**

4.OK = 4000 K  
6.OK = 6000 K

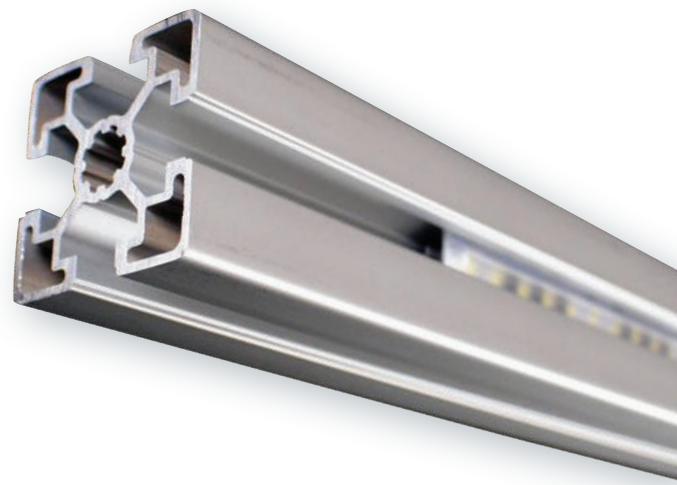
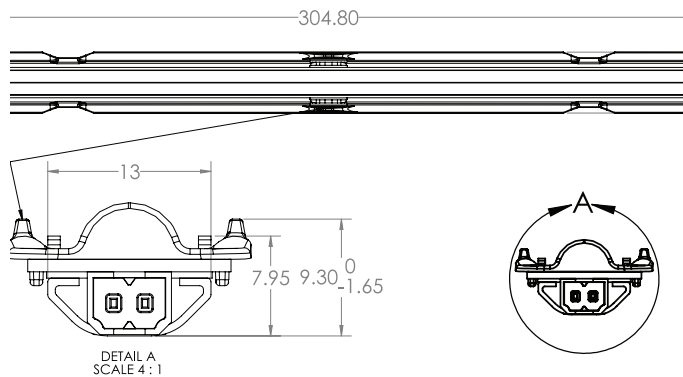

## Light Distribution Data

### TSLOT

WORKING DISTANCE meter (inches)	PATTERN (80%–100% measured intensity) millimeter (inches)
.5 m (~19.7")	550 mm (~21.7") H x 560 mm (~22") W
1 m (~39.4")	760 mm (~30") H x 760 mm (~30") W
1.5 m (~59.1")	971 mm (~38.2") H x 971 mm (~38.2") W
<b>Typical output performance</b>	
Distance = .5 m	<b>Illumination (Lux)</b> 1660

*Illumination measurement taken on White Lights – 6000 K*



## TSLOT Accessories



**5PM12-22P**  
TSLOT M12  
Pigtail Connector



**M8-TSLOT300-ADP**  
Extrusion Mounted  
M8 Power Connector

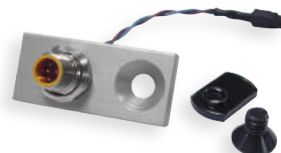

**M12-TSLOT300-ADP**  
Extrusion Mounted M12  
Power Connector



**TSLOT300-  
ENDSTOP**  
Extrusion mounted  
end stop for TSLOT



**TSLOT-DIM**  
Dimmer

# DLPW Front Light Series

## Diffuse Ring Light Panels | Washdown

The DLPW Front Light Washdown Series is specially designed for food industry and washdown environments where water and corrosive materials are present. The light offers a 65 mm camera hole in the center. Active area measurements include 190 mm x 190 mm, 300 mm x 300 mm, and 600 mm x 600 mm.

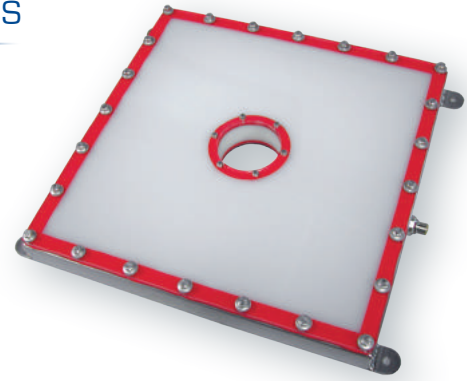

## DLPW Washdown Front Light Series Features

- Similar form and features as DLP
- Larger custom sizes available
- IP68 standards — meets FDA requirements
- 316 stainless-steel housing

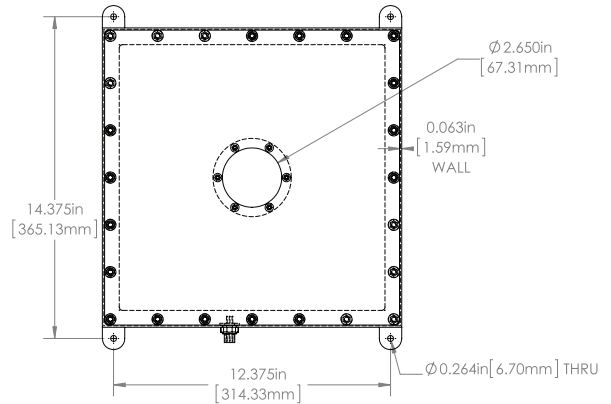
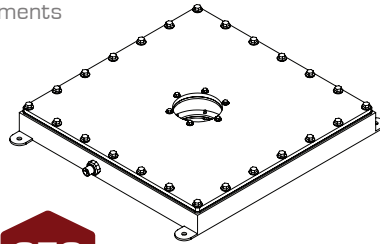

**PRODUCT FAMILY:**  
Diffuse Ring Light  
DLPW

**SIZE:**  
190 x 190  
300 x 300  
600 x 600

**COLOR:**  
470, 530, 625,  
850 & WHI  
(White)

**AVERAGE INTENSITY RATING**

30,000 lux\*

\*Lux measurement taken at surface of DLPW

## WASHDOWN LIGHT Application

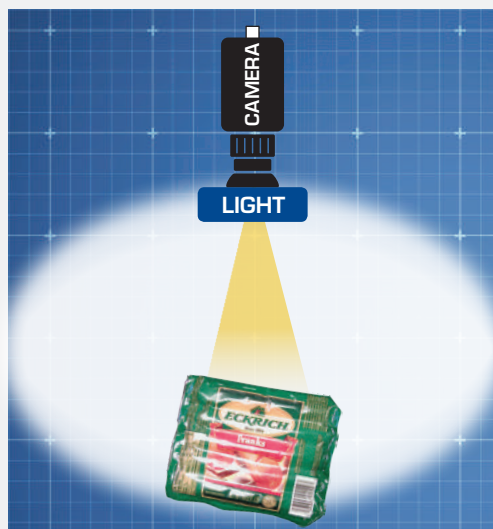

**Illumination:** DLPW Washdown Diffuse Panel Ring Light

### UNIFORM LIGHT FOR REFLECTIVE APPLICATIONS

#### Hot Dog Inspection

**CLIENT REQUEST:** Machine vision system to read a barcode and inspect the graphic image on a shiny food package.

**ISSUES:** Packaging is curved and reflective. All components must be washdown compatible to meet U.S. Food and Drug Administration (FDA) regulations.



Original packaging shown under normal lighting conditions



Example shown with Washdown Diffuse Ring Light Panel

**SOLUTION:** Smart Vision Lights is the only manufacturer of a washdown diffuse ring light panel that mimics a "light tent" or dome light for harsh environments. The diffuse ring light panel minimized the hot spots and reflections from the plastic package, allowing the vision system to successfully read the barcode and graphic detail on the plastic packaging.

# LW300 Linear Light

## Connect a Light | Washdown

The LW300 series features a 100 percent waterproof stainless-steel enclosure specially designed for food industry and washdown environments where water and corrosive materials are present. All circuitry is enclosed in an epoxy potting compound, further protecting the light from dust, debris, and all other contaminants. The LW300 is part of the Connect a Light Series of lights that simplify connecting multiple light segments together to create longer, larger illumination fields without the expense of large lights.

### LW300 Washdown Linear Light Features

- Similar form and features as L300
- IP68 standards – meets FDA requirements
- 316 stainless-steel housing

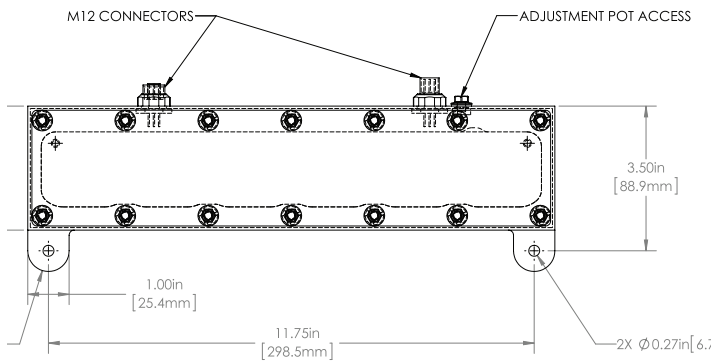

**PRODUCT FAMILY:**  
Linear Light  
LW300

**COLOR:**  
470, 505, 530, 625, 850,  
940 & WHI (White)

**LENSES:\***  
W = Wide  
L = Line

\*Narrow lens is standard

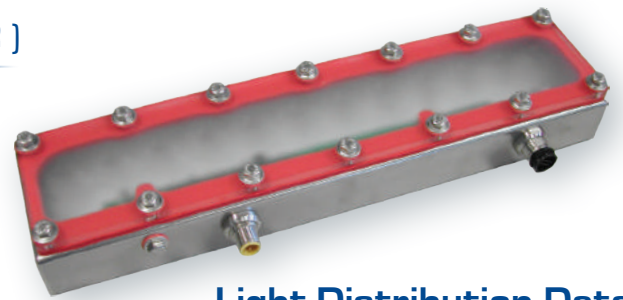

## Light Distribution Data

### LW300-XXX

WORKING DISTANCE meter (inches)	PATTERN (80%–100% measured intensity) millimeter (inches)
.5 m (19.7")	210 mm (~8") H x 100 mm (~4") V
1 m (39.4")	250 mm (~10") H x 200 mm (~8") V
1.5 m (59")	310 mm (~12") H x 300 mm (~12") V
Typical output performance	
Distance = .5 m	14000   OverDrive™ 70,000
Illumination measurement taken on White Lights – 6500 K	

### LW300-XXX-W

WORKING DISTANCE meter (inches)	PATTERN (80%–100% measured intensity) millimeter (inches)
.5 m (19.7")	220 mm (~9") H x 160 mm (~6") V
1 m (39.4")	460 mm (~18") H x 420 mm (~16.5") V
1.5 m (59")	570 mm (~22") H x 550 mm (~22") V
Typical output performance	
Distance = .5 m	6300   OverDrive™ 31,500
Illumination measurement taken on White Lights – 6500 K	

### LW300-XXX-L

WORKING DISTANCE meter (inches)	PATTERN (80%–100% measured intensity) millimeter (inches)
.5 m (19.7")	260 mm (~10") H x 100 mm (~4") V
1 m (39.4")	440 mm (~17") H x 190 mm (~7") V
1.5 m (59")	660 mm (~26") H x 300 mm (~12") V
Typical output performance	
Distance = .5 m	10000   OverDrive™ 50,000
Illumination measurement taken on White Lights – 6500 K	

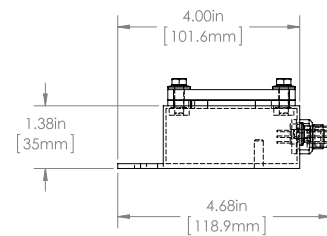

## ODLW300 OverDrive™ Linear Light Features

- Similar form and features as LW300
- Strobe-only OverDrive™ operation
- OverDrive™ units are 5x brighter than standard high-current LED lights
- Maximum strobe time 125 ms
- Up to 5000 strobes per second

**PRODUCT FAMILY:**  
Linear Light  
ODLW300 Series

**COLOR:**  
365, 395, 470, 505, 530,  
625, 850, 940 & WHI (White)

**LENSES:\***  
W = Wide  
L = Line

\*Narrow lens is standard

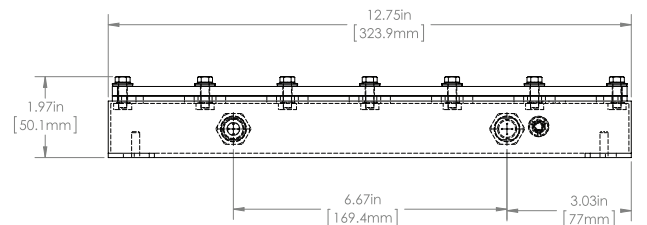
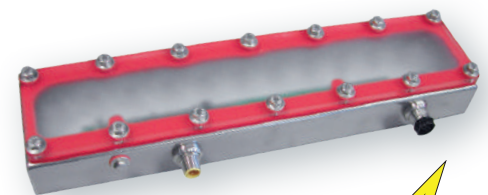

# SOBLW Backlight

## LED Backlights | Washdown

The SOBLW is a homogeneous backlight solution for harsh environments and operates in strobe or continuous mode. Comes in several sizes up to 450 mm x 300 mm (18" x 12") with larger custom items available.

### SOBLW Washdown Backlight Features

- Similar form and features as SOBL
- Highest level of uniformity
- IP68 rated – meets FDA requirements
- 316 stainless-steel housing

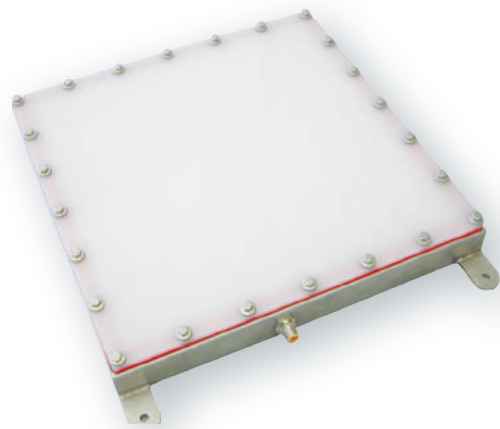

**AVERAGE INTENSITY RATING** 30,000 lux\*

\*Lux measurement taken at surface of SOBL

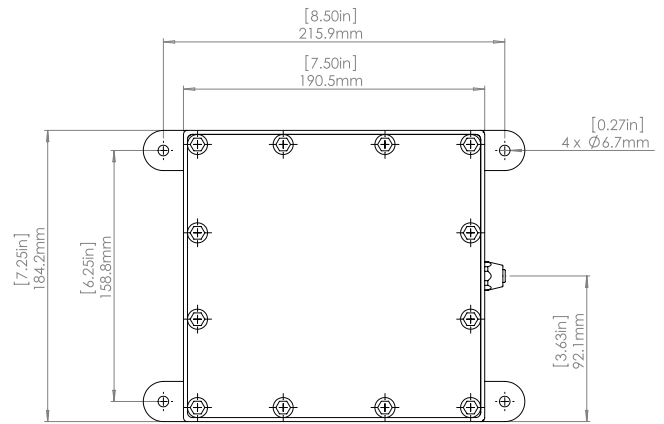
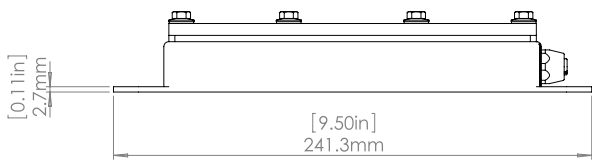

**PRODUCT FAMILY:**

Backlight  
SOBLW

**COLOR:**

470, 530, 625, 850 & WHI  
(White)



## DIFFUSE RING LIGHT

### Application



**Vision system:** Camsensor CS6

**Illumination:** DLPW-600x600-625

## LARGE RING LIGHT KEG INSPECTION

**CLIENT REQUEST** After beer kegs were refilled, some would leak from the ball valve on the top, adversely affecting client relations.

**ISSUES:** The client needed a washdown light that would keep fluids out while illuminating an in-line inspection system capable of inspecting the round beer keg top to find microcracks and small leaks at higher speeds than human inspectors could accomplish.



**SOLUTION:** After implementing an in-line keg inspection system at the production line, the customer was able to detect problematic microleaks, as well as damage or anomalies in keg spears. By detecting and removing faulty products at an early phase, customer complaints decreased by more than 50 percent.

# SW75 Brick Spot Light

## Brick Light | Washdown

The SW75 features a stainless-steel enclosure with sealed bolts and waterproof connector for applications in washdown and corrosive environments.

### SW75 Washdown Brick Spot Light Features

- Similar form and features as S75
- IP68 standards - meets FDA requirements
- 316 stainless-steel
- Designed to operate in food applications
- Corrosion-resistant

**PRODUCT FAMILY:**

Brick Light  
SW75

**COLOR:**

470, 505, 530, 625, 850,  
940 & WHI (White)

**LENSES:\***

W = Wide  
L = Line

\*Narrow lens is standard

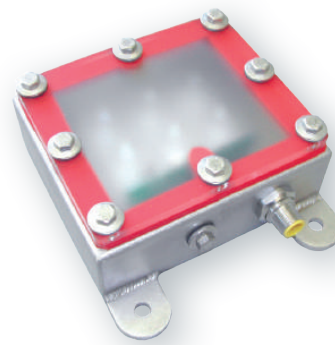

### Light Distribution Data

SW75-XXX

WORKING DISTANCE meter (inches)	PATTERN (80%–100% measured intensity) millimeter (inches)
.5 m (19.7")	100 mm (~4") D
1 m (39.4")	200 mm (~8") D
1.5 m (59")	300 mm (~12") D
Typical output performance	
Distance = .5 m	9600
<i>Illumination measurement taken on White Lights – 6500 K</i>	

SW75-XXX-W

WORKING DISTANCE meter (inches)	PATTERN (80%–100% measured intensity) millimeter (inches)
.5 m (19.7")	210 mm (~8") D
1 m (39.4")	425 mm (~17") D
1.5 m (59")	650 mm (~25") D
Typical output performance	
Distance = .5 m	6300
<i>Illumination measurement taken on White Lights – 6500 K</i>	

### ODSW75 Brick Spot Light Features

- Similar form and features as SW75
- Strobe-only OverDrive™ operation
- OverDrive™ units are 5x brighter than standard high-current LED lights



**PRODUCT FAMILY:**

Prox Light  
ODSW75

**COLOR:**

470, 505, 530, 625, 850,  
940 & WHI (White)

**LENSES:\***

W = Wide  
L = Line

\*Narrow lens is standard

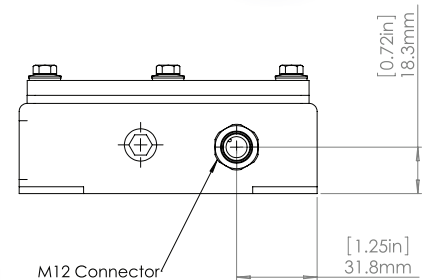
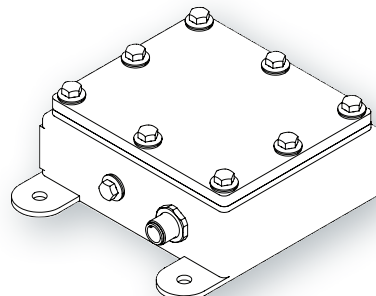
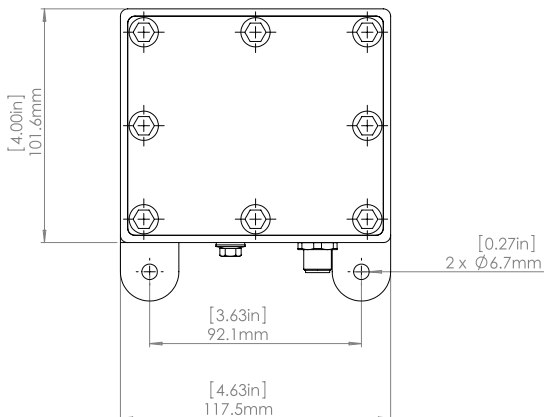
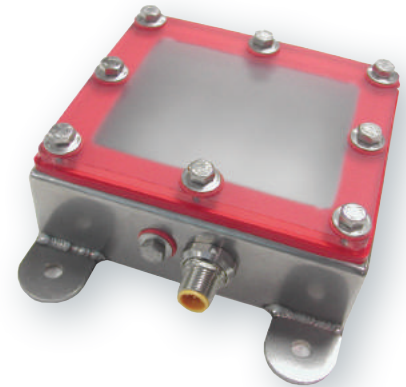

# SXW30 Prox Light Series

## Washdown 30 mm Barrel Spot Lights

The SXW30 Series features a stainless-steel enclosure for applications in washdown and corrosive environments.

### SXW30 Washdown Prox Light Features

- Similar form and features as SX30
- IP68 standards – meets FDA requirements
- 316 stainless-steel
- Corrosion-resistant

**PRODUCT FAMILY:**

Prox Light  
SXW30

**COLOR:**

365, 395, 470, 505, 530,  
625, 850, 940 & WHI (White)

**LENSES:\***

W = Wide  
L = Line

\*Narrow lens is standard

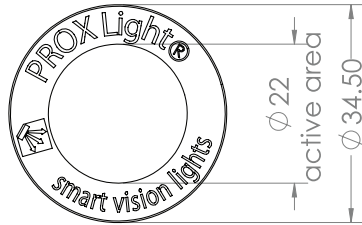
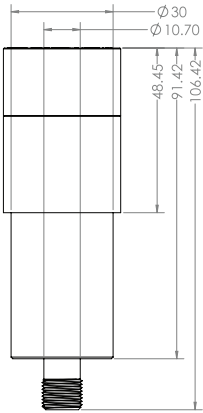

### Light Distribution Data

#### SXW30-XXX

WORKING DISTANCE meter (inches)	PATTERN (80%–100% measured intensity) millimeter (inches)
.5 m (19.7")	80 mm (~3") D
1 m (39.4")	185 mm (~7") D
Typical output performance	
Distance = .5 m	4200
	OverDrive™ 21,000
Illumination measurement taken on White Lights – 6500 K	

#### SXW30-XXX-W

WORKING DISTANCE meter (inches)	PATTERN (80%–100% measured intensity) millimeter (inches)
.5 m (19.7")	205 mm (~8") D
1 m (39.4")	415 mm (~16") D
Typical output performance	
Distance = .5 m	1300
	OverDrive™ 6500
Illumination measurement taken on White Lights – 6500 K	

#### SXW30-XXX-L

WORKING DISTANCE meter (inches)	PATTERN (80%–100% measured intensity) millimeter (inches)
.5 m (19.7")	255 mm (~10") H x 115 mm (~4.5") V
1 m (39.4")	460 mm (~18") H x 250 mm (~10") V
Typical output performance	
Distance = .5 m	1900
	OverDrive™ 9500
Illumination measurement taken on White Lights – 6500 K	



### ODSXW30 OverDrive™ Prox Light Features

- Similar form and features as SXW30
- Strobe-only OverDrive™ operation
- OverDrive™ units are 5x brighter than standard high-current LED lights
- 125 ms max pulse width
- Required 10% duty cycle for on/off time

**PRODUCT FAMILY:**

Prox Light  
ODSXW30

**COLOR:**

365, 395, 470, 505, 530,  
625, 850, 940 & WHI (White)

**LENSES:\***

W = Wide  
L = Line

\*Narrow lens is standard



## Adapters

### Step-Up/Down Adapter Kits

#### Ring Light Series

Step-up or step-down rings allow the M46 thread on Ring Lights to be mounted directly to the threads found on the front end of most lenses.



#### DF Series

Camera adapter 55, 60, and 34.9 to M46 adapter rings

#### SD Series

M46 step-down adapter rings. Lens thread sizes: 49, 52, 55, 58, 62, 67, 72

#### SU Series

M46 step-up adapter rings with 6 M2 set screws & hex wrench. Adapter sizes: 25.5-46, 27-46, 30.5-46, 34-46, 35.5-46, 37-46, 39-46, 40.5-46, 43-46,

## Cables

### Camera to Light

Smart Vision Lights offers a wide range of cable options. Its Camera to Light (CTL) Grey Series cable provides a directly wired connection between a single light and a camera. The CTL series is available for either steady/constant or flash/strobe connections, and the cables are available in lengths of 0.3 m and 2 m, with other lengths available by request.

The CTL Grey Series cables are compatible with Smart Vision Lights' OverDrive™ lights and offer a standard M8 and M12 connection. The CTL Grey Series steady/constant camera cable offers power and ground sync and is compatible with constant-operation lights made by Smart Vision Lights. The CTL Grey Series flash/strobe cable is compatible with Smart Vision Lights' OverDrive™ series of lights and offers power, ground, and flash sync.

The CTL Grey Series is available for cameras including:

- Baumer VeriSens® XC
- Cognex Dataman®
- Cognex In-Sight®
- Datalogic®
- SICK Inspector®
- Teledyne DALSA BOA®

See Camera to Light section for more details.



### Controller to Light

See Controller to Light section for more details.

## Color Testers

### Smart Color Box

#### Test Light Multicolor Tester

Materials respond to color in different ways. Sometimes the only way to know the color or wavelength that works the best is by testing different color lights. Purchasing each color LED light can be very expensive. The Smart Color Box tests the different colors that work best on your vision application for one-tenth the cost of buying six different colors of LED lights.



Simple to use: just push the button for the desired color. Works with standard CCD or CMOS cameras.

- 6 high-current LEDs: white, red 625 nm, blue 470 nm, green 530 nm, UV 395 nm, and IR 850 nm
- Li-ion battery with integrated charger/includes up to 2 hours of operation before recharging
- Recharges in 6 hours/includes recharging power adapter
- Push-button testing for LED on/off
- High-power, high-current LEDs

### S75-SCB-UV UV Color Box

- UV LEDs — 365 nm, 375 nm, 385 nm, 395 nm, and 405 nm
- Li-ion battery with integrated charger/ Up to 2 hours of operation before recharging
- Recharges in 6 hours/Includes recharging power adapter
- Push-button testing for LED on/off



## Controllers

### IVP-C1 Variable Control Pot

- Variable control remote pot for controlling the intensity of a Smart Vision Light.



## Diffusers and Polarizers

Available upon request.



## Filter Kit



The Smart Vision Lights Filter Kit offers a variety of imaging filters that are designed and manufactured for the most demanding machine vision applications. Imaging filters are used to improve or enhance the object under inspection. Smart Vision Lights filters are optimized for use with LED lights. Filters are available in multiple sizes and threads for easy mounting on standard machine vision lenses.

Each kit includes:

- 7 dichroic filters and 2 colorpass filters ranging from 470 nm–850 nm
- 1 polarizer filter with locking screw
- 27 mm filters with 2 adapter rings, 25.5 mm and 30.5 mm
- Transmission charts and curves detailing each bandpass filter and polarizer

## Light/Travel Kits

### Linear Light Kit L-Series

Linear Light Kit for L300 – segments, jumper, extrusion, hardware

### ODL-Series

OverDrive™ Linear Light Kit for ODL300 – segments, jumper, extrusion, hardware

### SVL Travel Kit (SVLK-100)

The SVL Travel Kit is a great tool to take along on sales demonstrations and for lab testing. Tailor your SVL Travel Kit by specifying the color of the lights you want. The kit contains lights and accessories, including:

- S30 Prox Light
- S75 Brick Light
- R80 Ring Light
- L300 Linear Connect a Light
- S75-SCB Smart Color Box
- SU46-25.5/27 Ring Light Adapter Kit
- T1 power supply (T2 optional)
- Carrying case
- SVLK-100-EURO Travel Kit is available with European power adapter and cable



## Mounts and Brackets

### BK Series

The BK Series includes camera mounting bracket for DLP/DLPC Diffuse Ring Light Panels.

### Linear Light Mounting Rail

## Power Supplies

### T1 Power Supply

- Tabletop 110 V AC power supply for lights
- 1.9 A
- M12 connection
- Travel adapters for Europe and Asia available



### T2 Power Supply

- Desktop 24 V DC power supply
- 9 A
- M12 connection
- Travel adapters for Europe and Asia available



## Pulse Modules

### PGM Stroboscope Module

This independent unit is a free-running pulse generator that causes an attached light to strobe at a set frequency without an NPN or PNP trigger. This unit easily integrates between your power source and LED array using a male-to-female M12 connection. It operates at a 10 percent duty cycle, meaning that the light will be active for 10 percent of the period and inactive for 90 percent. The pulse rate can be set to any frequency from 12 to 3200 Hz with two rotary dials. The first dial has 8 positions consisting of 12, 25, 50, 100, 200, 400, 800, and 1600 Hz. The second dial allows the user to finely adjust the frequency set by the first dial. This dial can be set up to two times the frequency of the first dial. The Stroboscope Module can be used on standard or OverDrive™ LED lights.



\*Din rail mountable

### PTM Module

Smart Vision Lights products are pulse-following and track a camera's lighting strobe signal. Some cameras are pulse-initiated and not pulse-following. High-speed cameras operate by initiating with a strobe pulse and then expect the light to hold output for a set time or duration. The Pulse-Initiated Timing Module accepts a pulse of 5  $\mu$ s or longer and holds the pulse for the selected duration. The PTM allows the user to select a pulse length from 7 preset durations of 20, 50, 100, 250, 500, 750 or 1,000 microseconds. The male M12 connector input connects to a camera, while female M12 output connects to a light.



\*Din rail mountable

# Filters

## Machine Vision Camera Filters

Bandpass filters allow users to control what their camera is seeing with greater contrast and a higher transmission for a reduced cost when compared to the conventional interference filter. Ideal for LED or laser diode application use. Common bandpass stock ranges from 25.5, 27, 30.5 and 46 mm.

### FS03-BP470 Blue Bandpass Filters

A very common filter, used for blue LEDs  
Useful Range: 440 nm–480 nm

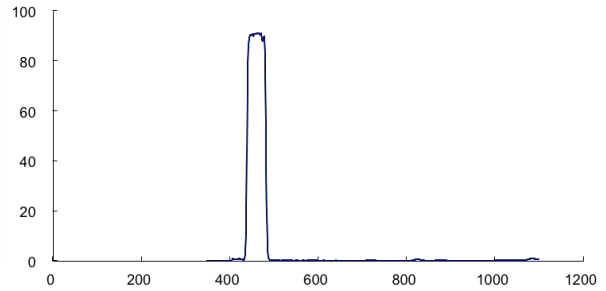

### FS03-BP505 Cyan Bandpass Filters

Used for cyan LEDs  
Useful Range: 470 nm–515 nm

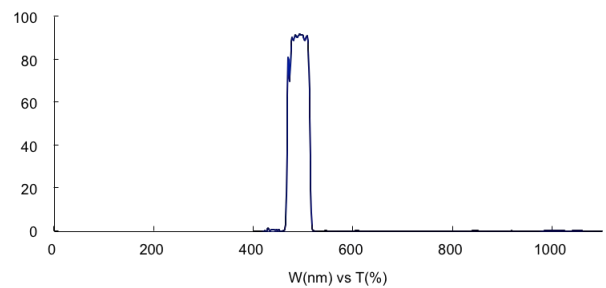

### FS03-BP525 Green Bandpass Filters

Mainly used for green LEDs  
Useful Range: 500 nm–540 nm

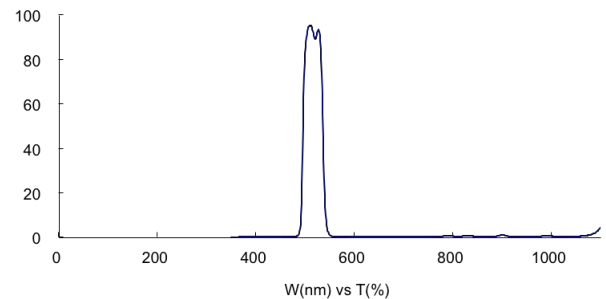

### FS03-BP590 Amber Bandpass Filters

Commonly used in amber or orange LEDs  
Useful Range: 580 nm–610 nm

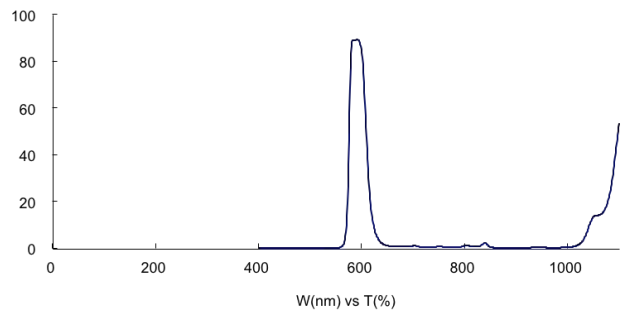

### FS03-BP850 IR Bandpass Filters

Infrared is used to maximize contrast under IR lighting  
Useful Range: 840 nm–870 nm

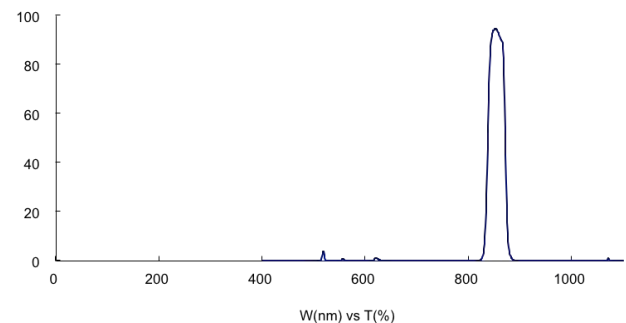

## FS03-BP635 Red Bandpass Filter

One of the most common filters, used for red LEDs  
Useful Range: 620 nm–660 nm

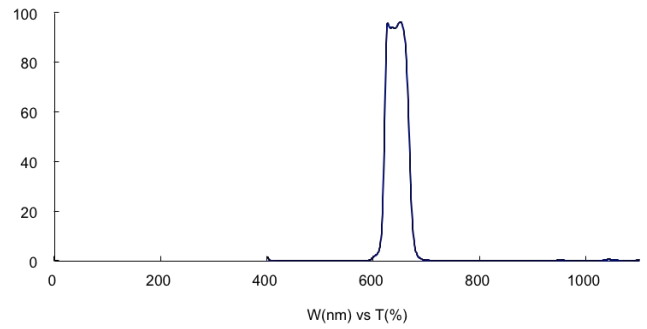

## FS03-BP660 Deep Red Bandpass Filters

Used for darker red LEDs  
Useful Range: 650 nm–680 nm

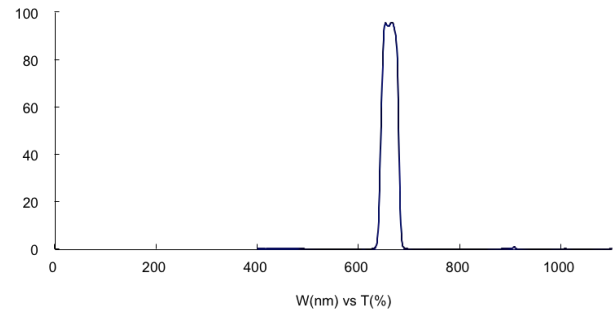

## FS01-BP635 Red Colorpass Filters

Used to allow red light to pass through  
Allows better angle of acceptance

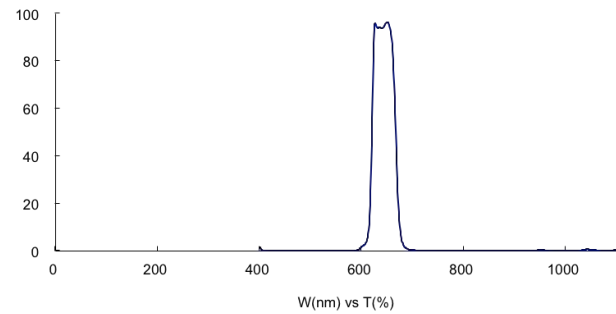

## FS01-BP660 Deep Red Colorpass Filters

Used for darker red LEDs  
More effective when high angle into camera

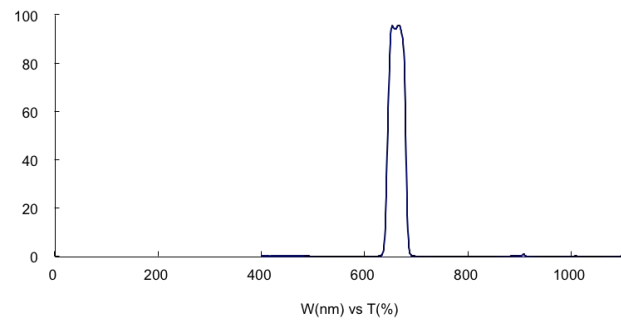

## FS03-PLR Linear Polarizer

Used to eliminate glare  
Comes with rotating locking screw to maximize versatility  
Useful Range: 400 nm–700 nm

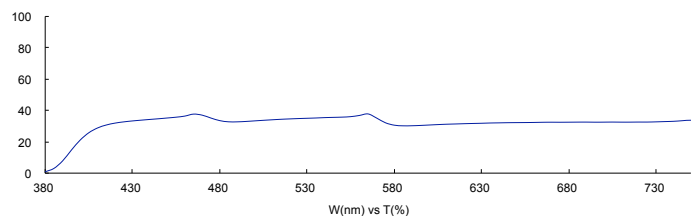







## SMART VISION LIGHTS COMPLIES WITH ALL INTERNATIONAL HUMAN SAFETY EYE AND SKIN STANDARDS ... AND WE CAN PROVE IT!

All LED lamps sold with the CE mark must be tested to international standard IEC/EN 62471 to prove that levels of UV and IR light do not pose a hazard to human eyes and skin.

In countries around the globe, IEC/EN 62471 compliance tests must be conducted by a Certification Body (CB) test lab before the manufacturer can legally apply a CE, CCC, or other conformity code.

Companies that place an LED light into service without IEC/EN 62471 compliance documentation run the risk of seizure and fines, among other potential liabilities.

Every product from Smart Vision Lights is IEC compliant. We can make that guarantee because Smart Vision Lights is one of the few industrial LED manufacturers to have its own IEC Light Testing Laboratory, certified by a National Certification Body (NCB).

Don't take risks. Let Smart Vision Lights help keep your customers and revenue stream safe through our extensive line of IEC/EN 62471-compliant lights.

"Cognex products needed to have a UL certification, and in order to obtain this, UL required Cognex to have our products IEC 62471/RP27-compliant.

**Smart Vision Lights** provided this proof of compliancy, further demonstrating their value as a lighting supplier in the machine vision industry."

— Nathan Caughel, Product Marketing Specialist,  
Cognex Corporation

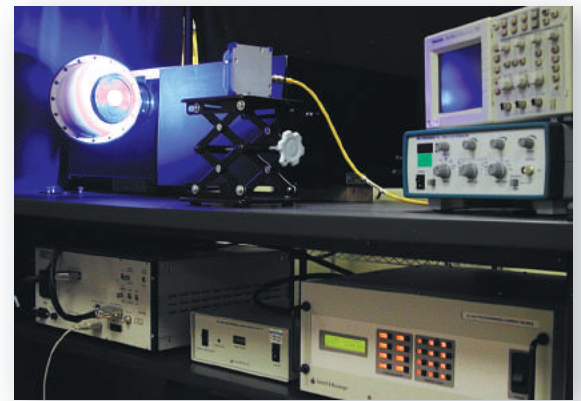



## smart vision lights

All **Smart Vision Lights** products are meticulously designed, assembled, and tested thoroughly before being shipped. Every **Smart Vision Lights** product is covered under our limited warranty for a period of 10 years\* (upon registration) from the date of shipping. We guarantee our products to be free of manufacture defects, both in the assembly process and the materials included in the design of our product. In the unfortunate case that a problem should occur during the warranty period, please contact the distributor that the light was purchased from or **Smart Vision Lights** directly as soon as possible. The appropriate steps will be taken to either repair or replace your product (at our option) at no charge. Failure to register the product will result in warranty defaulting to 5 years.

**Smart Vision Lights** will not assume responsibility for the misuse, obvious abuse, special, supplementary, consequential, or indirect damages of our products under this provision. Products showing any sign of disassembly or alteration, upon our inspection, are null and void of any warranty rights. Warranty is nontransferable. If the product inspected for warranty is deemed a manufacturer defect and covered under warranty, **Smart Vision Lights** will only cover ground shipping expenses for return of the item. **Smart Vision Lights** will not pay for expedited return shipping requests. If expedited return shipping is required, it must be paid for by another party.

\*All ultraviolet products are only subject to a 2-year limited warranty.



**smart  
vision lights**

*Where Innovation and Lighting Begin*

