

Macro lens

Componon 4.0/80-0003

For future tasks in industrial optics, the goal of Schneider-Kreuznach is to continue this tradition with modern, high-quality lenses in the field of digital applications. These lenses in their robust plastic housings are a good solution when using large linear and area sensors in a wide range of applications. A far-reaching and sophisticated optical design with constantly high manufacturing quality is a matter of course. The excellent optical coatings were designed specially for the glass types used. This ensures that the lens is optimally attuned to its application area. Flexible use due to the wide magnification range and the high optical quality with its logically limited starting aperture, low chromatic aberration and optimisation at small imaging distances all combine to make these lenses unique.



Componon 4.0/80

Key Features

- Excellent optical imaging performance when using large sensors
- 100% quality control guarantees reliability and constant quality
- Low maintenance requirements, therefore high system reliability

Applications

- Machine Vision and other imaging applications
- PCB inspection
- LCD inspection
- OLED inspection
- Solar inspection

Technical Specifications

F-number	4.0
Focal length	80.3 mm
Image circle	80.6 mm
Magnification	0.5 – 0.04
Transmission	400 - 700 nm
Interface	Leica-Mount
Weight	130 gr.
Option	Optical filter

Contact

Jos. Schneider Optische Werke GmbH
 Ringstraße 132
 55543 Bad Kreuznach
 Germany
 Phone +49 671 601-205
 Fax +49 671 601-286
www.schneiderkreuznach.com
industrie@schneiderkreuznach.com

Schneider Optical Technologies Co., Ltd.
 Rm. A505 Yingdali Science Park, Hongmian Rd.,
 Futian Free Trade Zone, Shenzhen 518038,
 P.R. China
 Phone: +86 755 88 32 11 70
 Fax: +86 755 88 32 11 75
www.schneiderkreuznach.com
info@schneider-asiapacific.com

Schneider Optics Inc.
 285 Oser Ave.
 Hauppauge, NY 11788
 USA
 Phone +1 631 761-5000
 Fax +1 631 761-5090
www.schneideroptics.com/industrial
industrial@schneideroptics.com

Componon 4.0/80

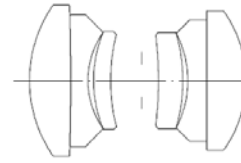
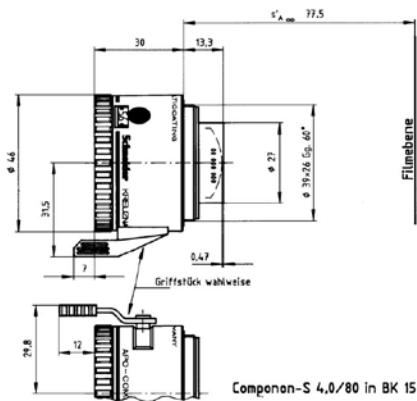

COMPONON-S 4.0/80

f^* = 80.3 mm	β_p^* = 1.027
s_F = -57.9 mm	s_{EP} = 20.3 mm
s_F^* = 64.7 mm	s_{AP}^* = -17.9 mm
HH^* = -1.8 mm	Σd = 36.3 mm

COMPONON-S 4.0/80

MODULATION with reference to the relative image height

Wavelength λ [nm] :	546	706	644	480	436	405
Spectral weighting [%] :	27.4	12.4	24.1	18.3	12.6	5.2
Spatial frequency R [1/mm] :	10	20	40			
Format [mm X mm] :	55.0	X	55.0			
Diagonal $2u'$ [mm] :	77.8					

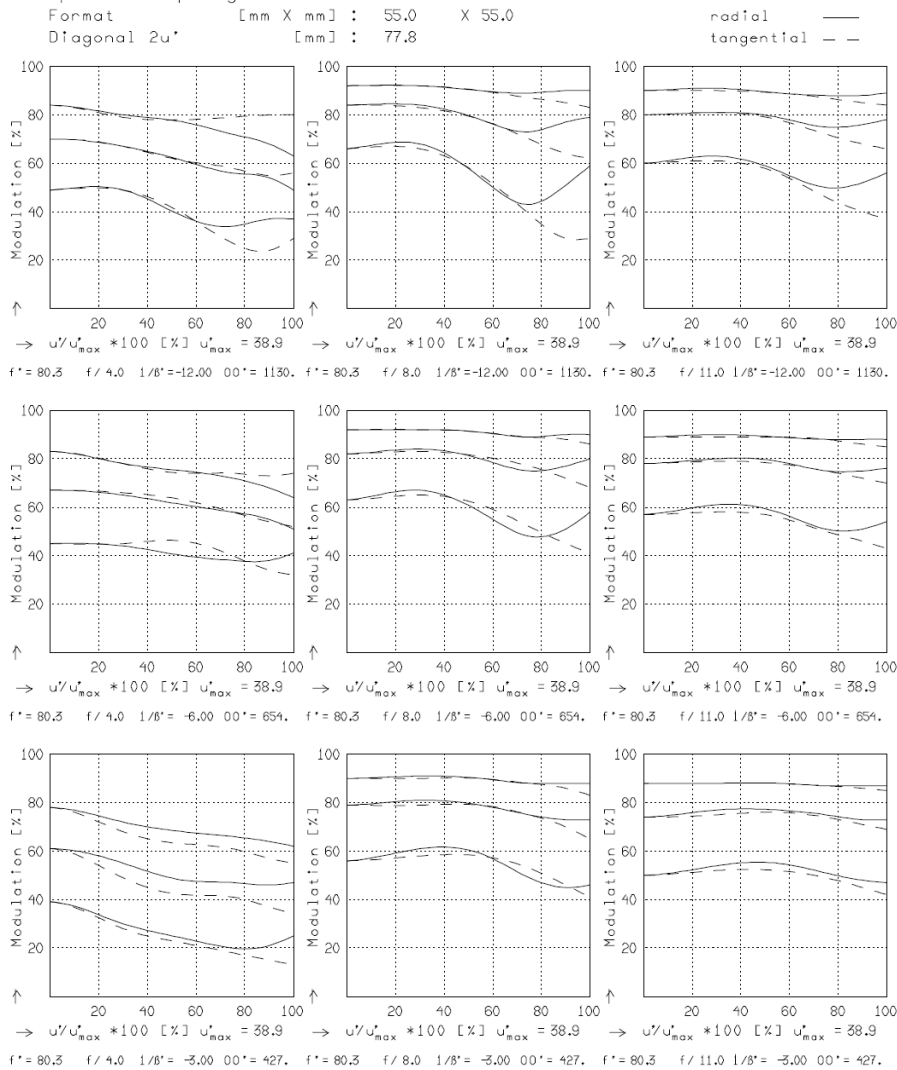

Focusing : MTF_{max} at f / 4.0 , R = 20 1/mm, $u'/u'_{max} = 0$

Componon 4.0/80

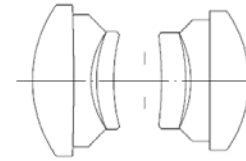
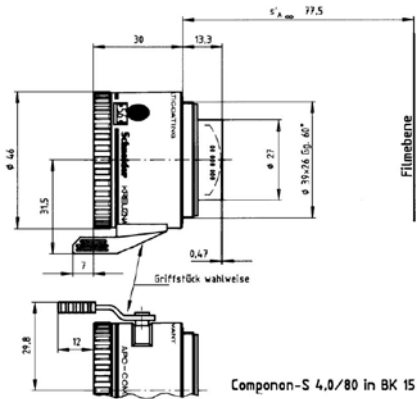

COMPONON-S 4.0/80

$f' = 80.3 \text{ mm}$	$\beta_p = 1.027$
$s_F = -57.9 \text{ mm}$	$s_{EP} = 20.3 \text{ mm}$
$s'_F = 64.7 \text{ mm}$	$s'_{AP} = -17.9 \text{ mm}$
$HH' = -1.8 \text{ mm}$	$\Sigma d = 36.3 \text{ mm}$

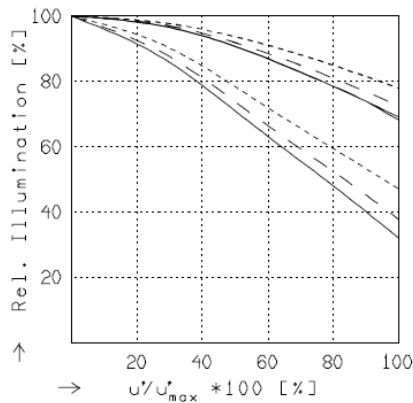

RELATIVE ILLUMINATION

The relative illumination is shown for the given focal distances or magnifications.

$f / 4.0$	$f / 8.0$	$f / 11.0$
-----------	-----------	------------

— $\beta' = -0.0833$	$u'_{max} = 38.9$	$00' = 1130.$
- - $\beta' = -0.1667$	$u'_{max} = 38.9$	$00' = 654.$
.... $\beta' = -0.3333$	$u'_{max} = 38.8$	$00' = 427.$

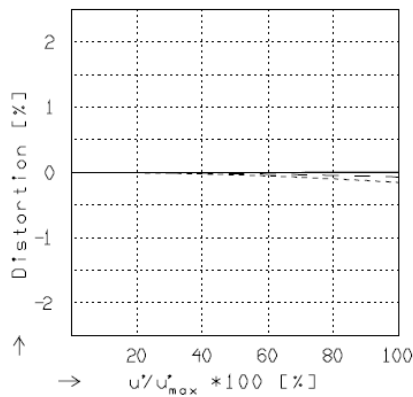

DISTORTION

Distortion is shown for the given focal distances or magnifications. Positive values indicate pincushion distortion and negative values barrel distortion.

— $\beta' = -0.0833$	$u'_{max} = 38.8$	$00' = 1130.$
- - $\beta' = -0.1667$	$u'_{max} = 38.8$	$00' = 654.$
.... $\beta' = -0.3333$	$u'_{max} = 38.8$	$00' = 427.$

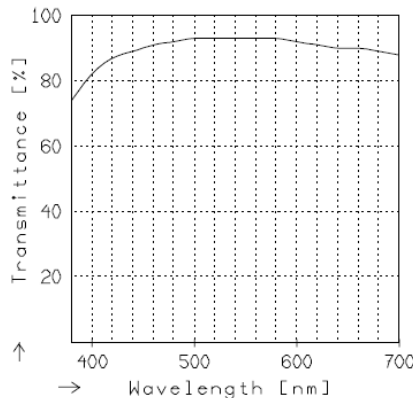

TRANSMITTANCE

Relative spectral transmittance is shown with reference to wavelength.